



Operator's Manual



INFPT Clock, Timer Controller

PREFACE

Manual Objectives

This manual shows you how to set up and use the INFPT (Clock/Timer/Controller).

In this manual we provide procedures for:

- * Setting the setpoints
- * Setting the clock
- * Setting the date
- * Setting up a timer unit
- * Setting up a start value
- * Setting up a stop value
- * Setting up a count range cycle
- * Calibrating the meter
- * Entering the CONTROLLER OUTPUT mode
- * Entering AM/PM setup for setpoint configuration
- * Setting up serial communications menu items
- * Installing a battery board
- * Setting the meter to default settings (if settings have been changed)

Table A-1. Sections of the Manual

Table A-1. Sections of the Manual (Continued)

NOTES, WARNINGS and CAUTIONS

Table A-1. Sections of the Manual

If you want to read about:		Refer to section
Unpacking and safety considerations	1	Introduction
Meter description and features	2	About the Meter
Power-Up Initialization; power failure; checking & installing main board jumpers and meter power	3	Getting Started
Basic procedures that include setting up setpoints; setting up the clock; date; timer unit; start/stop value; and count range cycle.	4	Configuring the Meter
Configuring menu items; defining display prompts	5	Menu Items
Referencing default values; setting default values (if defaults have changed)	6	Default Setup
Attaching an external battery	7	Attaching an External Battery
Wiring P2 connectors	8	Wiring the P2 Control Input/Outputs
Synchronizing the internal real time clock	9	Synchronizing the Internal Real Time Clock
Calibrating the meter	10	Calibrating the Meter

Information that is especially important to note is identified by three labels:

- * **NOTE**
- * **WARNING**
- * **CAUTION**

NOTE: provides you with information that is important to successfully setup and use the INFPT.

CAUTION: tells you of circumstances or practices that can effect the timer's functionality.

Table A-1. Sections of the Manual (Continued)

Reviewing the timer's internal settings	11	Reviewing the Timer's Internal Settings
Selecting a timer unit	12	Configuring Timer Units
Selecting 2 or 3 wire timer control	13	Selecting Timer Control
Setting up non-pattern (independent; elapse; pause) & pattern modes (independent; ganged); Configuring AM/PM setpoints; setting up a fall-back pattern	14	Configuring Controller Output Modes
RS-232/RS-485/Communication classes/point-to-point mode/multi-point mode/phone jack hook-up information, command types/formats/Hex ASCII format	15	Interfacing Serial Communications
Isolated parallel BCD output board: specifications, jumper functions, P8 assignments, enabling transmission of BCD data; multiplex; board address	16	Isolated Parallel BCD Output Board
Dual relay output board: specifications; jumper functions	17	Dual Relay Output Board
Four relay output board: specifications; jumper functions	18	Four Relay Output Board
Installing a battery back-up board	19	Attaching a Battery Back-Up Board

WARNING: tells you of circumstances or practices that can lead to personal injury as well as damage to equipment.

ABOUT THE METER (Continued)

Figure 2-2. Exploded View of Meter with Optional Housing

Table of Contents

Section		Page
SEC 1	INTRODUCTION	
1.1	Unpacking	
1.2	Safety Considerations	
SEC 2	ABOUT THE METER	
2.1	Description	
2.2	Features	
SEC 3	GETTING STARTED	
3.1	Initialization Check	
3.2	Recovering from Power Disconnect/Power Failure	
3.3	Checking and Installing Main Board Jumpers	
3.4	Selecting Meter Power	
SEC 4	BASIC PROCEDURES - CONFIGURING THE METER	
4.1	Setting the Setpoints	
4.2	Setting the Clock	
4.3	Setting the Date	
4.4	Setting up a Timer Unit	
4.5	Setting up a Start Value	
4.6	Setting up a Stop Value	
4.7	Setting up a Count Range Cycle	
SEC 5	MENU ITEMS	
5.1	Configuration Menu Items	
5.2	Display Prompts	
SEC 6	DEFAULT SETUP	
6.1	Default Values	
SEC 7	ATTACHING AN EXTERNAL BATTERY	
SEC 8	WIRING THE P2, CONTROL INPUT/OUTPUTS	
SEC 9	SYNCHRONIZING THE INTERNAL REAL TIME CLOCK	
SEC 10	CALIBRATING THE METER	
SEC 11	REVIEWING THE METER'S INTERNAL SETTING	
SEC 12	CONFIGURING TIMER UNITS	
SEC 13	SELECTING TIMER CONTROL	
13.1	3-Wire Control: Start, Stop and Reset	
13.2	2-Wire Control: ON (run gate) and Reset	
13.3	Logic Input Information for 2 and 3-Wire Control	
SEC 14	CONFIGURING CONTROLLER OUTPUT MODES	
14.1	Non-Pattern Modes	
14.1.1	Independent Mode (INDEP)	
14.1.2	Elapse Mode (ELAPSE)	
14.1.3	Pause Mode (PAUSE)	
14.1.4	Door Control Example	
14.2	Pattern Control	

Table of Contents

Section		Page
14.2.1	Independent Pattern Mode (INDPAT)	
14.2.2	INDPAT Mode Example	
14.2.3	Ganged Pattern Mode (GANPAT)	
14.2.4	Cycle Testing	
14.2.5	Pattern Group "Edit" Programming Example	
14.2.6	Fall-Back Pattern	
SEC 15	INTERFACING SERIAL COMMUNICATIONS	
15.1	Serial Communication Specifications	
15.2	RS-232 Hardware	
15.3	RS-485 Hardware	
15.4	Sending Commands	
15.4.1	Communication Classes	
15.4.2	Command Types	
15.4.3	Command Formats	
15.4.4	Point-to-Point Format Explanation	
15.4.5	Multi-Point Format Explanation	
15.4.6	HEX ASCII Format	
15.5	Serial Communication Menu Items	
15.5.1	BAUD (Baud Rate)	
15.5.2	SERCNF (Serial Configuration)	
15.5.3	DAT FT (Data Format)	
15.5.4	BUS FT (BUS Format)	
15.5.5	SER AD (RS485 Serial Device Address)	
15.5.6	SER TI (Serial Time)	
15.6	Serial Communication Command Structure	
15.6.1	Command Class Letter Abbreviations	
15.6.2	Single Commands	
15.7	Command Suffixes	
15.8	Serial Parameter Values	
15.8.1	Suffix "01"	
15.8.2	Suffix "02"	
15.8.3	Suffix "03"	
15.8.4	Suffix "04"	
15.8.5	Suffix "05"	
15.8.6	Suffix "06"	
15.8.7	Suffix "07"	
15.8.8	Suffix "08"	
15.8.9	Suffix "09", "0A", "0B", "0C", "0D", "0E", "0F", "10"	
15.8.10	Suffix "11"	
15.8.11	Suffix "12"	
15.8.12	Suffix "13"	
15.8.13	Suffix "14"	
15.8.14	Suffix "15"	
15.8.15	Suffix "16"	
15.8.16	Suffix "17"	
15.8.17	Suffix "18"	
15.8.18	Suffix "19"	
15.8.19	Suffix "1A, 1B, 1C, 1D, 1E, 1F, 20, 21"	
15.8.20	Suffix "22"	
15.8.21	Suffix "23"	
15.8.22	Suffix "24"	
15.8.23	Suffix "25"	
15.8.24	Suffix "26"	
15.9	Meter Reset Through Serial Communications	
15.10	Status Character Formats	

Table of Contents

Section	Page
15.11	“^AE” Response Format
15.12	Meter Communication in the CONTINUOUS Mode
15.12.1	“V01” Response Data Format
15.13	External Print Command
15.14	Serial Communications Error Messages
15.15	RS-485 CONTROLLER Mode
15.16	ASCII Codes
SEC 16	ISOLATED PARALLEL BCD OUTPUT BOARD
16.1	Specifications
16.2	Jumper Locations and Configurations
16.3	50-Line Cable Compatibility
16.4	Enabling Transmission of BCD Data
16.5	(not) Hold Control
16.6	(not) Data Ready Timing Pulses
16.7	Bringing Out the BCD Alarm Lines
16.8	Three-Digit-At-A-Time Multiplex
16.9	Six-Digit-At-A-Time Board Address
16.10	Selecting Data Polarity: Jumper S8
16.11	Applying Non-Isolated Power
16.12	Driving a Printer
SEC 17	DUAL RELAY OUTPUT BOARD
17.1	Specifications
17.2	Jumper Locations and Configurations
SEC 18	FOUR RELAY OUTPUT BOARD
18.1	Specifications
18.2	Jumper Relay Assignments
SEC 19	BATTERY BACK-UP BOARD
19.1	Battery Board Installation
SEC 20	ERROR MESSAGES
SEC 21	METER SPECIFICATIONS

List of Figures

Figure	Page
2-1	Exploded View of Meter with Standard Bezel
2-2	Exploded View of Meter with Optional Housing
2-3	Connector Label
2-4	Front-Panel Display and Buttons
7 3-1	Main Board Jumpers
3-2	AC Power Plug Wiring
7-1	Rear View of Meter with 4-Relay Board and Serial Communications
7-2	Rear View of Meter with BCD and Serial Communications
13-1	3-Wire Timer Control
13-2	2-Wire Timer Control
14-1	INDEP Mode Flowchart
14-2	INDEP Setpoint Illustration
14-3	ELAPSE Mode Flowchart
14-4	ELAPSE Setpoint Illustration

14-5	PAUSE Mode Flowchart
14-6	PAUSE Setpoint Illustration
14-7	INDPAT Mode Flowchart
14-8	INDPAT Setpoint Illustration
14-9	GANPAT Mode Flowchart
15-1	RS-232 Serial Communications Board
15-2	RS-485 Serial Communications Board
15-3	4-Wire RS-232 Connections
15-4	RJ-11 and RJ-12 Connectors
15-5	Multi-Point Half-Duplex RS-485 Connection
15-6	Multi-Point Full-Duplex RS-485 Connection
16-1	BCD Board Jumper Locations
17-1	Dual Relay Output Board
18-1	4 Relay Board Jumper Locations
18-2	4 Relay Board Installation
19-1	Battery Board Jumper and Battery Locations
21-1	Panel Dimensions
21-2	Panel Mount Assembly with Standard Bezel
21-3	Meter Dimensions with Standard Bezel
21-4	Panel Mount Assembly with Optional Housing
21-5	Meter Dimensions with Optional Housing

Table of Tables

Section	Page
A-1	Sections of the Manual
2-1	Front Panel Part Description
3-1	Main Board Jumper Reference
3-2	Main Board Jumper Functions
3-3	AC Power Connections
5-1	Configuration 1 (CNFG 1) Menu Items
5-2	Configuration 2 (CNFG 2) Menu Items
5-3	Timer Units Display Selections
8-1	P2 Connector Functions
11-1	Meter Review Display Description
12-1	Timer Unit Selection
14-1	Door Control Example Description
14-2	Door Control Example, Independent Output Control Mode
14-3	Door Control Example, Elapsed Output Control Mode
14-4	Setpoint/Pattern Relationship (Independent Pattern Mode)
14-5	INDPAT Mode Example, Time Periods/Output States
14-6	INDPAT Mode Example, Setpoints/ Output Switch Pattern Inputs
14-7	Ganged Pattern Description
15-1	Telephone Jack to Computer Hookup Information
15-2	Telephone Jack to Printer Hookup Information
15-3	Half-Duplex Hookup to the Computer
15-4	Full-Duplex Hookup to the Compute
15-5	HEX ASCII Conversion Information
15-6	Data Format Options
15-7	BUS Format Options
15-8	Command Class Letters
15-9	Single Commands
15-10	Command Suffixes
15-11	Character/Alarm States
15-12	Serial Communication Error Message
15-13	ASCII Codes
16-1	BCD Board Jumpers/Functions
16-2	P8 Assignments

16-3	CF1.5 AND CF1.6 Output Configurations
17-1	Dual Relay Board Jumpers
18-1	4 Relay Board Jumpers
20-1	Error Messages

SECTION 1. INTRODUCTION

1.1 UNPACKING

Remove the Packing List and verify that all equipment has been received. If there are any questions about the shipment, contact the NEWPORT Customer Service Department at 1-800-NEWPORT (800-639-7678) or (714) 540-4914.

Upon receipt of shipment, inspect the container and equipment for any signs of damage. Take particular note of any evidence of rough handling in transit. Immediately report any damage to the shipping agent.

Note: The carrier will not honor any claims unless all shipping material is saved for their examination. After examining and removing contents, save packing material and carton in the event reshipment is necessary.

Verify that you receive the following items:

QTY DESCRIPTION

1	INFPT Clock/Timer controller with all applicable connectors attached.
1	INFPT Owner's Manual
1	Set Mounting brackets

1.2 SAFETY CONSIDERATIONS

- * The meter is protected in accordance with Class II of IEC 348 and VDE 0411
- * The meter has no power-on switch, so it will be in operation as soon as you apply power

CAUTION: Do not expose your meter to rain or condensing moisture. Do not operate your meter in flammable or explosive atmospheres.

SECTION 2. ABOUT THE METER

2.1 DESCRIPTION

The INFPT is a multi-functional panel meter that may be set up as a clock/timer controller or stopwatch. The unit contains a total of 8 different time bases and a built-in date function. The meter employs five CONTROLLER OUTPUT modes. These modes allow setup in virtually any timer control application. Eight setpoints may cycle through pre-set configurations up to 999,999 times. The INFPT is appropriate for life test cycling - turning four loads on and off, based on a timing cycle. The external START/STOP/RESET input lines may be set up as a stopwatch timer. The clock time base derives power from a 50 or 60Hz powerline and from an internal crystal oscillator.

Configure and access the meter via front-panel pushbuttons. You may also access these features via RS-232 or RS-485 serial communications.

2.2 FEATURES

INFPT's features:

- * Six-digit, 14 segment LED display
- * Microprocessor-based, with nonvolatile memory
- * Configure via front panel push-buttons and/or through RS-232 or RS-485 serial communications.
- * Alphanumeric display prompts
- * One button, scrolling review of setup parameters
- * Eight built-in time bases
- * .01 second resolution
- * COUNT UP or COUNT DOWN mode
- * Five CONTROLLER OUTPUT modes
- * Internal storage of eight output switch pattern groups
- * Real Time clock, plus date with leap year correction
- * Optional battery back-up board (in case of power failure)
- * Optional relay, BCD and serial communication plug-in boards.

ABOUT THE METER (Continued)

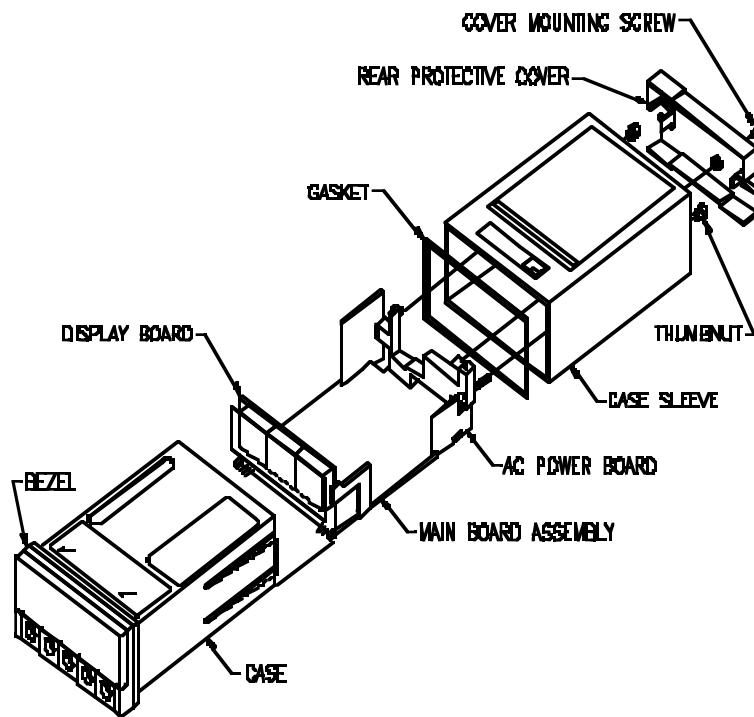
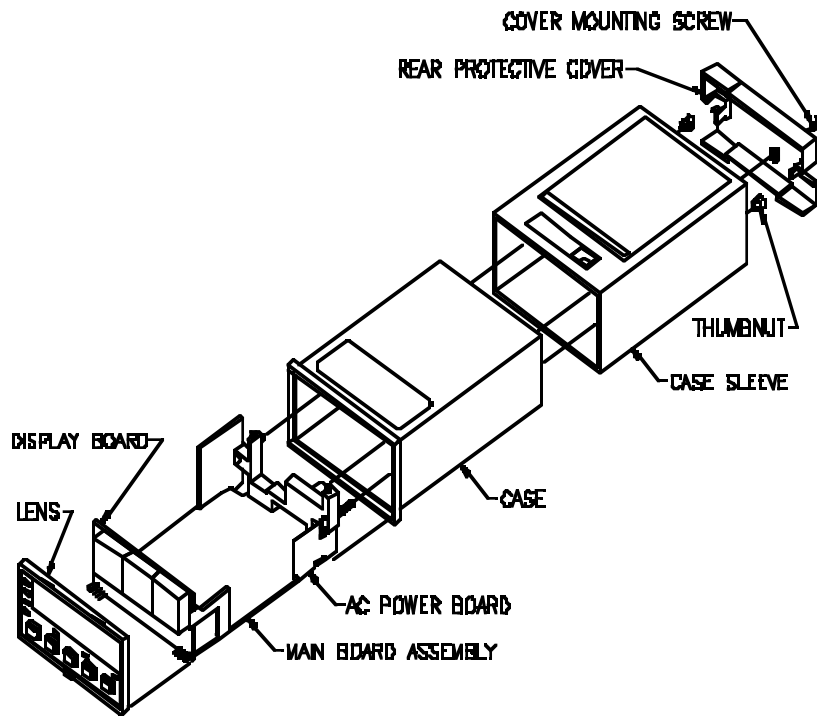

Figure 2-1. Exploded View of Meter with Standard Bezel

ABOUT THE METER (Continued)



P2/CABLE CONNECTOR

AL1	1	2	+V EXT
ALE CUT	3	4	AL2
AL3	5	6	AL4
PULSE OUT	7	8	+5V
GND EXT	9	10	LOCKOUT EEPROM
PRINT COMMAND	11	12	NONSTANDARD RX
NONSTANDARD TX	13	14	GND
N/C	15	16	N/C
EXT CAL1	17	18	EXT CAL2
N/C	19	20	EXT BAT+

P4/RS232

6	N/C
5	COMM GND
4	RX
3	TX
2	RTS
1	N/C

P4/RS485

6	N/C
5	B ₋ RX
4	A ₊ RX
3	COMM GND
2	B ₋ TX/RX
1	A ₊ TX/RX

2 RELAY

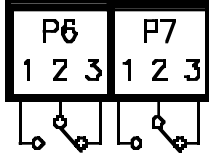

4 RELAY

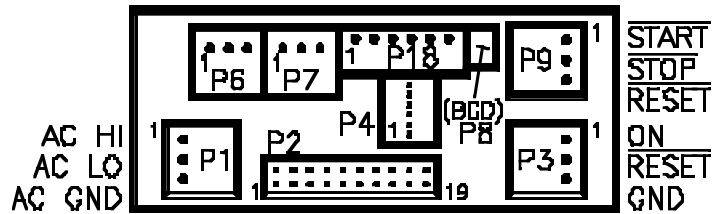
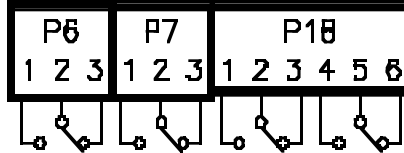

ABOUT THE METER (Continued)

The front panel displays values and messages with 6, 14 segment LEDs. Refer to Table 2-1 for a detailed description of each button and its corresponding description or function.

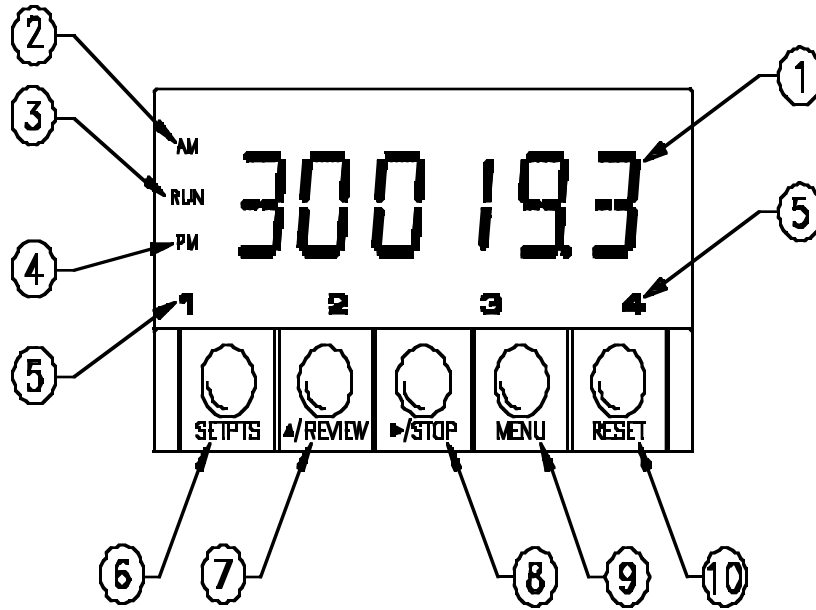

PARTS OF THE METER (Continued)

PARTS OF THE METER (Continued)

Table 2-1. Front Panel Part Description

Item	Button/Feature	Description/Function
1	Display	6-Digit, 14-segment, 0.54-inch LED.
2 3 4	"AM" "RUN" "PM"	12-HR REAL TIME CLOCK mode indicates AM. Indicates when timer is running. 12-HR REAL TIME CLOCK mode indicates PM.
5	Setpoint LEDS	Red LEDS; designates active alarm outputs.
6	"SETPTS"	View or change the eight (8) setpoints.
7	"REVIEW"	In the RUN mode, checks the current internal settings of the timer, determines current cycle number and/or verifies stop value. Meter continues its timing cycle and control functions. In the MENU mode, press with the STOP button to make meter configuration changes.
8	"STOP"	In the RUN mode, toggles the timing cycle between stop and resume. The RUN LED lights every time the timer is running. <i>Note: For the STOP button to start and stop the timer, set configuration bit "CF2.1=0".(refer to Section 7, Timer Control Selection).</i> In the MENU mode, press with the REVIEW button to make meter configuration changes.
9	"MENU"	In the RUN mode, functions similar to the enter key on a computer keyboard; enters the MENU mode and makes meter configuration changes. <i>Note: If you enter the MENU mode and do not press any buttons for 3 minutes (or longer) the meter automatically switches to the run mode (except when you are in the calibration routine).</i>
10	"RESET"	In the RUN mode, pre-sets the timer display back to the pre-configured START value. <i>Note: If you program the timer to display the Real Time clock, the RESET button has no function.</i> In the MENU or SETPOINT CHANGE mode, functions as an escape key to go back one menu item at a time. Press button quickly twice to access the RUN mode.

SECTION 3. GETTING STARTED

3.1 INITIALIZATION CHECK

Verify that the meter is set up to run with the correct power voltage (115 Vac or 230V ac +/- 10%). The unit has no power-on switch, so it will be in operation as soon as you apply power. Once you apply power the meter performs an initialization check (self-test). The initialization check consists of the following and takes place in this order:

1. Segment test - all 14-segments momentarily display.
2. LED test - all annunciator LED's and alarm output LED's momentarily display.
3. Version verification - Current microprocessor version momentarily appears.
4. Battery verification - "BAT IN" displays if battery back-up board is installed. Refer to Section 7 for additional information about the battery back-up board.

Meter switches to the configured time-base after initialization routine.

Press the **RESET** button to begin a new timing cycle.

3.2 RECOVERING FROM POWER DISCONNECT/POWER FAILURE

Meter retains memory (without battery back-up) for the following:

Date
Real Time
Current Cycle value
Timer Display value

This means that the meter stores information to the EEPROM when the unit encounters a power disconnection or power failure. When power is restored the meter resumes its previous mode prior to power failure. The timer display flashes, indicating a power failure has occurred. Press the **RESET** button to stop display flashing. Press the **REVIEW** button to reveal current setup parameters.

The AM/PM LEDs flash until the Real Time display is reset to the correct time.

Note: If the unit has a battery back-up board, refer to Section 7.

3.3 CHECKING AND INSTALLING MAIN BOARD JUMPERS

This section contains figures and instructions for checking and installing jumpers for the main board only. The default setup is for S1A and S2A to be in the stored position.

Table 3-1. Main Board Jumper Reference

If You Have	Refer to Section
Isolated Serial Communications Board	15
Isolated Parallel BCD Output Board	16
Dual Relay Output Board	17
Four Relay Output Board	18

3.3 CHECKING AND INSTALLING MAIN BOARD JUMPERS (Continued)

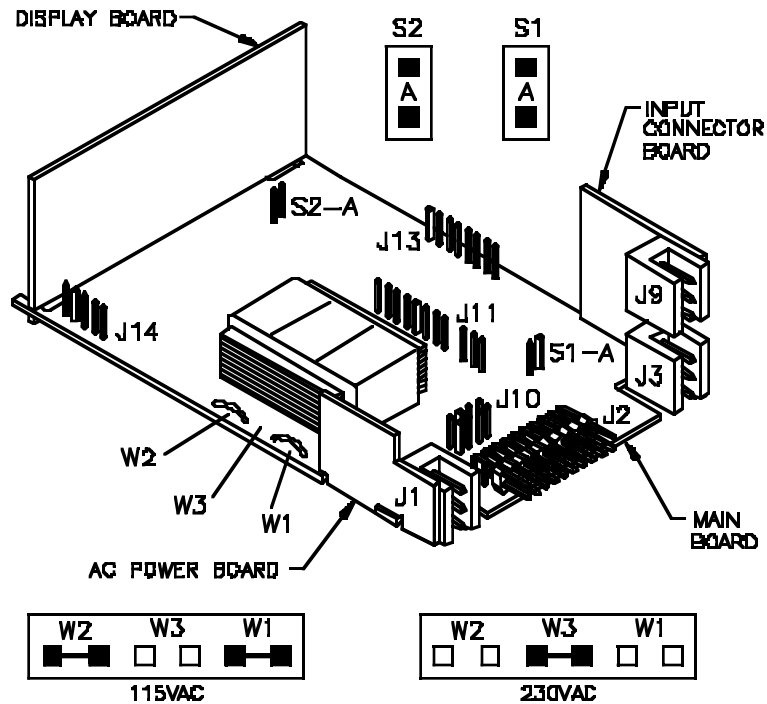

Table 3-2. Main Board Jumper Functions

Jumper	Function
S1-A	Disables pushbutton programming
S2-A	Enables storage of calibration factor by connecting P2-17 to P2-18
W1, W2, & W3	Enables 115V/230V operation

Note: S2A determines if P2-17 and P2-18 are operative.

3.4 SELECTING METER POWER

If your line voltage is 115Vac, install jumpers W1 and W2 (but not W3).
 If your line voltage is 230Vac, install jumper W3 (but not W1 or W2).

If your line frequency is 60Hz, you must set the software switch
 "CF2.2=0".

If your line frequency is 50Hz, you must set the software switch
 "CF2.2=1".

CAUTION: AN INCORRECT CF2.2 SWITCH SETTING MAY CAUSE THE METER TO KEEP INACCURATE TIME.

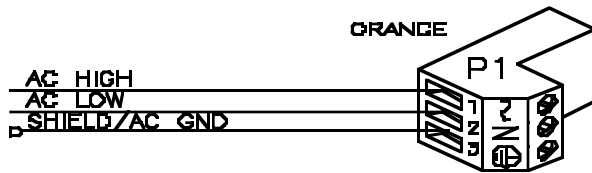

Figure 3.2 AC power plug wiring

Wire Color USA	Wire Color International	Connection	Connector PIN Socket
Black	Brown	ac High (HI)	1
White	Blue	ac Low (LO)	2
Green	Green/Yellow	ac GND	3

Table 3-3. AC Power Connections

SECTION 4. BASIC PROCEDURES - CONFIGURING THE METER

4.1 SETTING THE SETPOINTS

1. Press the **SETPTS** button. The meter displays "STPT 1", followed by the actual setpoint 1 value (left-most digit flashing).
Note: If you do not press any buttons for approximately 20 seconds the meter automatically switches into the run mode.
2. Press the **REVIEW** button to change the digit's value and the **STOP** button to move horizontally through the display.
3. Press the **SETPTS** button to store new setpoint values.
Note: Once you store the setpoint value the meter automatically advances to the next setpoint.
4. If you wish to return to the **RUN** mode, press the **RESET** button.

4.2 SETTING THE CLOCK

1. Press the **MENU** button until "12/24H" appears.
2. Select either a 12 or 24-hour clock. Press the **STOP** button to toggle between 12 and 24.
3. Press the **MENU** button to store the time. The meter displays "TIMSET".
4. Press the **STOP** button. The meter displays actual time value (left-most digit flashing).
5. Press the **REVIEW** button to change the digit's value and the **STOP** button to move horizontally through the display. Continue to use the **REVIEW** and **STOP** button until hours, minutes and seconds are correct.
6. Press the **MENU** button to store new time to nonvolatile memory. If you set up a 12-hour clock, the meter displays "AM/PM". If you set up a 24-hour clock, the meter displays "DATE".
7. If "AM/PM" appears, press the **STOP** button to toggle between AM and PM, then press the **MENU** button to store either AM or PM. The meter then displays "DATE".

4.3 SETTING THE DATE

1. Press the **MENU** button until "DATE" appears.
2. Press the **STOP** button. The Month displays.
3. Press the **REVIEW** button to scroll forward and the **STOP** button to scroll backward through all possible months.
4. Once correct, press the **MENU** button to store the month. The day of the month then appears, with left-most digit flashing.
5. Press the **REVIEW** button to change the digit's value and the **STOP** button to move horizontally through the display.
6. Once the date appears correct, press the **MENU** button to store new date. The meter then displays "YR XXXX", with the actual year flashing.
7. Press the **REVIEW** button to scroll forward and the **STOP** button to scroll backward through the years (range is 1990 through 2053).
8. Once correct, press the **MENU** button to store the year.

4.4 SETTING UP A TIMER UNIT

A timer unit is a measure of time. If "START" does not display as a menu item, the timer unit is set to real time (refer to Section 12 for more information on timer units). To set up a timer unit, follow these steps:

1. Press the **MENU** button until "UNITS" appear.
2. Press the **STOP** button to display the current timer unit.
3. Press the **STOP** button to scroll through available timer units. To be able to set up start and stop values, select one of the following timer units:

- * "DD.HH.MM" (1 min resolution)
- * "MM.SS.SS" (.01 sec resolution)
- * "HHHHHH" (1 hr resolution)
- * "HHHH.HH" (.01 hr resolution)
- * "MMMM.MM" (.01 min resolution)
- * "SSSS.SS" (.01 sec resolution)

4.4 SETTING UP A TIMER UNIT (Continued)

4. Press the **MENU** button to store. Continue to press the **MENU** button until "START" displays to set up a start value.

Note: Before setting up a start or stop value as a setpoint you may want to view current setpoint values. To do so press the SETPTS button. "STPT 1" displays momentarily, followed by the actual setpoint value. Continue to press the SETPTS button to scroll through values for setpoints 2 through 8.

4.5 SETTING UP A START VALUE

A start value is the beginning of a count range cycle (refer to Section 4.6). If you press the **RESET** button while in the **RUN** mode, the meter resets to the previously set start value. You may program the START value with one of three values: ZERO or LARGEST, SETPOINT VALUE or any valid value. To program:

1. Press the **MENU** button until "START" appears.
2. Press the **STOP** button. One of the following displays:
 - * "LARGEST" - if you previously set up count down direction
 - * "ZERO" - if you previously set up count up direction
- 3a. If you select the start value to be either LARGEST or ZERO, press the **MENU** button to store LARGEST or ZERO. Meter displays "STOP" (to set up a stop value).
- 3b. If you select the start value to be a setpoint, follow these steps:
 1. Press the **STOP** button. The meter displays "SP NO".
 2. Press the **MENU** button. The meter displays "SP 1".
 3. Press the **STOP** button to scroll through setpoint selections until desired setpoint value displays (example: "SP 3").
 4. Once correct, press the **MENU** button to store the setpoint selection. Meter displays "STOP" (to set up a stop value).

4.5 SETTING UP A START VALUE (Continued)

3c. If you select the start value to be a number, follow these steps:

1. Press the **STOP** button. The meter displays "SP NO".
2. Press the **STOP** button again. The meter displays "IN NO".
3. Press the **MENU** button. Enter a valid input value (press the **REVIEW** button to scroll through number options and the **STOP** button to scroll horizontally through the display).
4. Once correct, press the **MENU** button to store the number start value. Meter displays "STOP" (to set up a stop value).

4.5 SETTING UP A STOP VALUE

A stop value is the end of a count range cycle (refer to Section 4.6). Like the start value, you may set up a stop value only if you configure the meter to use a timer unit other than Real Time. You may program the timer to stop at a setpoint (SP1 through SP8) or any number (up to the maximum value for the timer).

1a. If you select the stop value to be a setpoint, follow these steps:

1. Press the **STOP** button. The meter displays "SP NO".
2. Press the **MENU** button. The meter displays "SP 1".
3. Press the **STOP** button to scroll through Setpoint selections until desired setpoint value displays (example: "SP 3").
4. Once correct, press the **MENU** button to store the setpoint selection. Meter displays "CYCLE".

1b. If you select the stop value to be a number, follow these steps:

1. Press the **STOP** button. The meter displays "SP NO".
2. Press the **STOP** button again. The meter displays "IN NO".
3. Press the **MENU** button. Enter a valid input value (press the **REVIEW** button to scroll through number options and the **STOP** button to scroll horizontally through the display).
4. Once correct, press the **MENU** button to store the number stop value. The meter displays "CYCLE".

4.6 SETTING UP A COUNT RANGE CYCLE

Each instance that the timer resets to "START" and then counts to "STOP" is one count range cycle. You may set up CYCLE values only if you configure the meter to use a time-base other than the Real Time clock (refer to Table 6-1). You may program the meter to cycle through its count range a predetermined number of times, up to 999999 times.

1. Press the **MENU** button until "CYCLE" appears (a main menu item).
2. Press the **STOP** button. The current cycle number appears, with left-most digit flashing.
3. Press the **REVIEW** button to change digit values. Press the **STOP** button to scroll horizontally through the cycle number display.

SETTING UP A COUNT RANGE CYCLE

4. Once the correct cycle number displays, press the **MENU** button to store the value.

The most significant digit is the left-most digit. You may enter any value from 0 to 9 for any digit position. You may also enter an "F" for the most significant digit position **only**. "F" allows you to set up an infinite (forever) cycle. If you enter an "F" in the most significant digit position the meter does not read any of the other digit values. It cycles forever.

If you set up the cycle as "000000" the meter defaults to "000001". If you select the meter to cycle forever the meter cycles to "999999", then rolls over to "000000" and starts over. If you set up the meter to cycle to "999999", the meter cycles to "999999" and then stops.

Once all cycles are complete, meter switches to the Real Time clock display and disables any setpoint comparison.

SECTION 5. MENU ITEMS

5.1 CONFIGURATION MENU ITEMS

Table 5-1. Configuration 1 (CNFG 1) Menu Items

"CF1.1="	<p>0 = Enables display & setting of all setpoint values. 1 = Disables display & setting of all setpoint values.</p>
"CF1.2="	<p>0 = Enables display & setting of all serial communication parameters. 1 = Disables display & setting of all serial communication parameters.</p>
"CF1.3="	<p>0 = Enables display & setting of all menu items. 1 = Disables display & setting of all menu items.</p>
"CF1.4="	<p>0 = Enables EEPROM storage of changed settings. 1 = Disables EEPROM storage of changed settings.</p>
"CF1.5="	<p>0 = No BCD board installed. 1 = BCD board is installed.</p>
"CF1.6="	<p>0 = Output timer display value to BCD board. 1 = Output Real Time value to BCD board.</p>
"CF1.7="	<p>0 = 100% LED brightness level. 1 = 50% LED brightness level.</p>
"CF1.8="	<p>0 = Disables RS-485 CONTROLLER mode 1 = Enables RS-485 CONTROLLER mode</p> <p><i>Note: CF1.8 is only valid in conjunction with RS-485 communication option board. (refer to Section 15.15 for more information on the RS-485 CONTROLLER mode).</i></p>

Note: Factory default settings are bold.

5.1 CONFIGURATION MENU ITEMS (Continued)

"CF2.1="	0 = Enables front panel start/stop control. 1 = Enables external (TB3,TB9) start/stop control.
"CF2.2="	0 = 60 Hz line frequency. 1 = 50 Hz line frequency.
"CF2.3="	0 = Enables fallback pattern. 1 = Disables fallback pattern.
"CF2.4="	0 = Enables front panel RESET (in RUN mode). 1 = Disables front panel RESET (in RUN mode).
"CF2.5="	0 = Use line frequency for Real Time clock. 1 = Use internal crystal for Real Time clock.

Table 5-2. Configuration 2 (CNFG 2) Menu Items

Note: Factory default settings are bold.

5.2 DISPLAY PROMPTS

12/24H Set up (or change) a 12 or 24-hour clock. Press the **STOP** button to toggle between 12 and 24, and the **MENU** button to store your selection.

TIMESET Set up (or change) Real Time. Press the **STOP** button to display the current Real Time. Press the **REVIEW** button to change the digit's value and the **STOP** button to move horizontally through the display. Press the **MENU** button to store your entry.

AM/PM Set up (or change) AM or PM. This prompt only appears if the meter is set up for a 12-hour clock. Press the **STOP** button toggle between AM and PM, and the **MENU** button to store your selection

DATE Access the internal date function. Press the **STOP** button to display the currently used month.

APP Set up (or change) the month. Press the **REVIEW** button to scroll forward and the **STOP** button to scroll backward through all possible months. Press the **MENU** button to store.

APP 06 Set up (or change) the day. Press the **REVIEW** button to change the digit's value and the **STOP** button to move horizontally through the display. Press the **MENU** button to store.

YR 1992 Set up (or change) the year. Press the **REVIEW** button to scroll forward and the **STOP** button to scroll backward through

the years (range is 1990 through 2053). Press the **MENU** button to store.

IN CTL Access timer control selection.

3W SSR Select 3-wire timer control (3-wire Start/Stop/Reset). Press the **STOP** button to toggle between 3-wire and 2-wire control. Press the **MENU** button to store.

2W DNR Select 2-wire timer control (2-wire On and Reset). Press the **STOP** button to toggle between 2-wire and 3-wire control. Press the **MENU** button to store.

UNITS Access Controller Timer Units selection. To indicate the UNITS choices uniquely, two displays are available. DISPLAY-1 and DISPLAY-2 appear alternately. DISPLAY-1 will flash for approximately 2.5 seconds, and DISPLAY-2 will appear, but not flash, for 1.5 seconds. Press the **STOP** button to scroll through timer unit selections. Press the **MENU** button to store.

Table 5-3. Timer Units Display Selections

#	Display-1	Display-2 (Max Values)	Notes
1	"DD.HH.MM"	"99.23.59"	1 minute resolution
2	"HH.MM.SS"	"12.59.59"	12-hr Real Time clock (count up only!)
		"23.59.59"	24-hr Real Time clock (count up only!)
3	"HH.MM.SS"	"99.59.59"	1 second resolution
4	"MM.SS.SS"	"99.59.99"	.01 second resolution
5	"HH HH HH"	"999999"	1 hour resolution
6	"HH HH.HH"	"9999.99"	.01 hour resolution
7	"MM MM.MM"	"9999.99"	.01 minute resolution
8	"SS SS.SS"	"9999.99"	.01 second resolution

5.2 DISPLAY PROMPTS (Continued)

SP OPT Access setpoint (SP) options (**CONTROLLER OUTPUT** modes). Press the **STOP** button to scroll through the 5 modes. Press the **MENU** button to store the value.

INDEP Select the setpoints to INDEPENDENTLY control the outputs. For example:

- SP 1 turns ON output 1
- SP 2 turns OFF output 1
- SP 3 turns ON output 2
- SP 4 turns OFF output 2
- SP 5 turns ON output 3

ELAPSE Select the even numbered setpoints to control the ELAPSED (ON) time of the outputs. For example:

- SP 1 turns ON output 1
- SP 2 sets the "ON TIME" of output 1
- SP 3 turns ON output 2
- SP 4 sets the "ON TIME" of output 2
- SP 5 turns ON output 3

PAUSE Select the even numbered setpoints to control the PAUSE (OFF) time of the outputs. For example:

- SP 1 turns OFF output 1
- SP 2 sets "OFF TIME" of output 1
- SP 3 turns OFF output 2
- SP 4 sets "OFF TIME" of output 2
- SP 5 turns OFF output 3

INDPAT Select INDEPENDENT PATTERN control. Timer starts with all outputs in the OFF state. When the timer encounters SP 1, Pattern 1 is active for outputs 1 through 4. When the timer encounters SP 2, Pattern 2 is active for outputs 1 through 4. Setpoints 1 through 8 are the start times of patterns 1 through 8 respectively.

GANPAT Select GANGED PATTERN control. Timer starts with all outputs in the OFF state. When the timer encounters SP 1, Pattern 1 is active for outputs 1 through 4. Once the timer encounters SP 1, Pattern 1 is active for the time equal to SP1+SP2 (SP1-SP2 in **COUNT DOWN** mode). The OFF time of Pattern 1 is the start time of Pattern 2. Pattern 2 is active for the time equal to SP2+SP3 (SP2-SP3 in **COUNT DOWN** mode), etc.

PASEL Access Pattern Group selection (**Appears only if you set up INDPAT or GANPAT modes**).

5.2 DISPLAY PROMPTS (Continued)

PGPP=A Select a pattern group. Press the **STOP** button to scroll through the 8 available pattern groups pre-programmed into the meter's non-volatile memory. Press the MENU button to store your selection. The selected P.GRP will be used by the **INDPAT** and **GANPAT** modes.

CNTDIR Access controller timer count direction.

CNT UP Select count direction. Press the **STOP** button to toggle between "COUNT UP" and "COUNT

CNT DN "DOWN". Press the **MENU** button to store your selection.

START Access counter START number selection.

ZERO Start at zero count. Appears only if you select count up direction.

LARGST Start at the largest available count. Appears only if you select count down direction.

SP NO Access the ability to select a setpoint as the counter START number. Appears only if you select Independent (**INDEP**) mode.

SP 1 Select a setpoint as the counter START number. Press the **STOP** button to scroll through setpoint options. Press the **MENU** button to store your selection.

IN NO Access the ability to input any valid number as the actual START number.

000000 Select a valid number as the actual start number. Display depends on the UNITS (timebase) you select.

STOP Access counter STOP number selection.

SP NO Access the ability to select a setpoint as the counter STOP number. Appears only if you select Independent (**INDEP**) mode.

SP 1 Select a setpoint as the counter STOP number. Press the **STOP** button to scroll through setpoint options. Press the **MENU** button to store your selection.

5.2 DISPLAY PROMPTS (Continued)

IN N Access the ability to input any valid number as the actual STOP number.

000000 Select a valid number as the actual STOP number. Display depends on the UNITS (timebase) you select.

CYCLE Access cycle selection. Each instance that the timer resets to "START" and then counts to "STOP" is a "count range cycle". You may set up CYCLE values only if you configure the meter to use a UNIT (timebase) other than the Real Time clock (refer to Table 12-1).

00000 Select a number of cycles. You may program the meter to cycle through its count range a predetermined number of times, up to 999999 times. You may also enter an "F" as the most significant digit (left-most digit) to set up an infinite (forever) cycle.

PGEDIT Access Pattern Group Edit selection. Displays only if you select Independent Pattern or Ganged Pattern controller output mode.

GPP= Select a group to create or edit. You may save 8 pattern groups in non-volatile memory. Press the **STOP** button to scroll through group numbers. Press the **MENU** button to store your selection.

160000 Create or edit a pattern group. The following example defines each digit position:

Example: "16.0000"

1 = Pattern Group Number (1 in this case)
Valid group numbers: 1 through 8

6 = Pattern Number (6 in this case)
Valid pattern numbers: 1 through 8

0 = State of output 1 (directly to the right of the decimal point)

0 = State of output 2

0 = State of output 3

0 = State of output 4

Valid states: (0=OFF, 1=ON)

You may edit 8 pattern numbers at one time. Press the **STOP** button to scroll through available choices. Press the **MENU** button to save new/changed entries. Press the **RESET** button to exit out of this menu.

SERSET Access SERIAL COMMUNICATIONS submenu. (refer to Section 15, Serial Communications).

5.2 DISPLAY PROMPTS (Continued)

CALIB Access **CALIBRATION FACTOR** mode. Appears only if S2-A is installed and P2-17 to P2-18 is connected). Press the **STOP** button to display the current **CALIBRATION** factor. Press the **REVIEW** button to change the digit's value and the **STOP** button to move horizontally through the display (refer to Section 10, Calibration).

5.2 DISPLAY PROMPTS (Continued)

FALBANK Access Fall-Back Pattern selection.

F00000 Change the Fall-Back Pattern. The following example defines each digit position. FB represents Fall-Back and may not be changed.

Example: **FB.0000**

0 = State of output 1 (directly to the right
of the decimal)

0 = State of output 2

0 = State of output 3

0 = State of output 4

Valid states: (0=OFF, 1=ON)

SECTION 6. DEFAULT SETUP

Throughout this manual default (factory) settings are bolded. You may recall the default settings and **store them** in the EEPROM memory at any time.

WARNING: THE FOLLOWING SETUP PROCEDURE ERASES ANY PREVIOUSLY STORED CUSTOM CONFIGURATIONS. THIS DEFAULT SETUP PROCEDURE WILL NOT WORK IF BATT-BACK UP IS INSTALLED.

1. Turn off ac power to meter.
2. Press the two outside buttons (**SETUP** and **RESET**) simultaneously.
3. While pressing both buttons, turn on the ac power to initiate the default setup. Meter momentarily displays "SETUP".
4. Release the **SETUP** and **RESET** buttons immediately. The meter then continues to operate with the default configuration.

Note: This setup procedure does not change the 8 pattern groups or the calibration factor.

6.1 DEFAULT VALUES

Units selected:	MM MM.MM (.01 min)
SP OPT:	INDEP mode
START number:	00 00.00
STOP number:	00 00.10
CYCLE limit:	000010
FALLBACK pattern:	0 0 0 0
SETPOINT #1:	00 00.01
SETPOINT #2:	00 00.02
SETPOINT #3:	00 00.03
SETPOINT #4:	00 00.04
SETPOINT #5:	00 00.05
SETPOINT #6:	00 00.06
SETPOINT #7:	00 00.07
SETPOINT #8:	00 00.08
Pattern group used: 01	
Date:	01 Jan 1991
COUNT UP mode	
3-wire control	
24-HR CLOCK mode	
Serial cnfg:	9600 Baud, Odd parity, 2 stop bits
Serial address:	001
Serial recog:	*
Serial TI:	000001
Serial delay:	30mS

Note: International customers: set "CF2.2=1" for 50Hz operation.

SECTION 7. ATTACHING AN EXTERNAL BATTERY

P2 pin 20 (+V) allows you to power the meter by attaching an external battery, or using a dc power supply. The return of the battery or power supply connects to P2-9 (gnd). You may apply voltage on P2 anywhere between 6 Vdc and 12 Vdc, with a maximum current draw of 150 mA.

When you power the meter via the external +V power input, the serial communications board does not operate. The serial communications board is not powered by this +V pin. The meter **does not** store Real Time, date and CUCYC values to EEPROM if the dc power is lost. The meter uses the crystal timebase to update the internal Real Time and date functions.

During normal operation off ac power, you may use the meter to trickle-charge (Thru P2-20) a NiCad battery (customer-furnished).

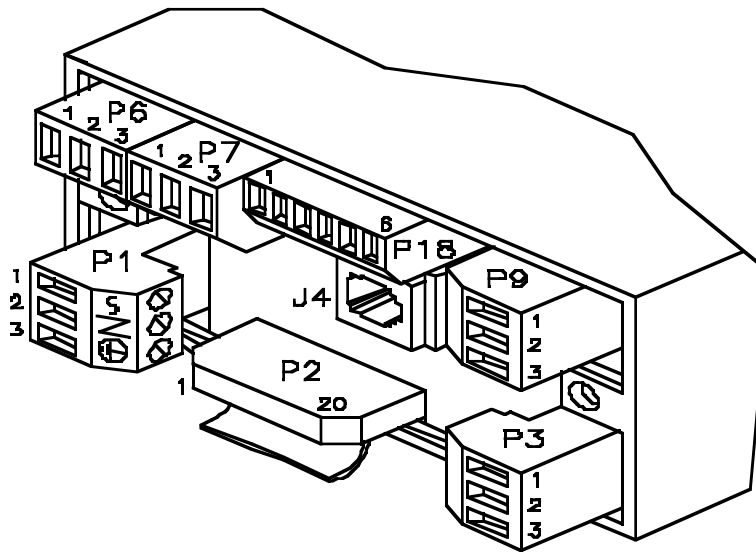
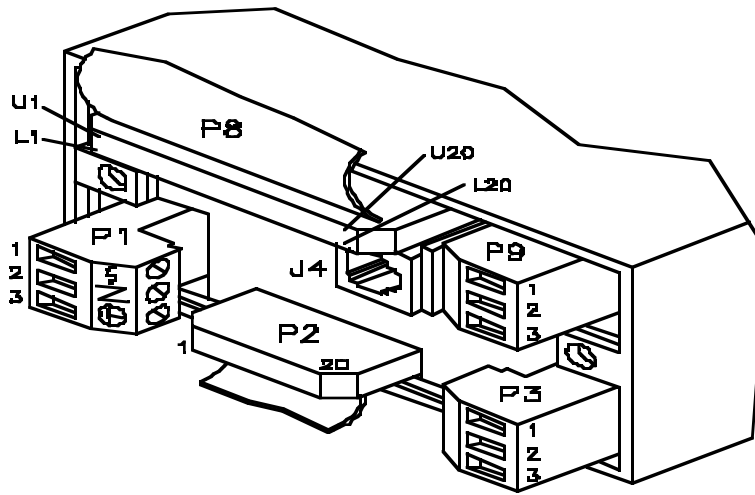

Figure 7-1. Rear View of Meter with 4-Relay Board and Serial Communications

SECTION 7. ATTACHING AN EXTERNAL BATTERY (Continued)



SECTION 8. WIRING THE P2, CONTROL INPUT/OUTPUTS

P2, the 20-socket ribbon connector (refer to Figure 7-1/7-2), sends out alarm transistor collectors and permits remote control of meter features.

Table 8-1. P2 Connector Functions

Pin #	Function
P2-1	Alarm 1 transistor open collector output.
P2-2	Input of external V+ for Alarm transistors.
P2-3	1.843200 Mhz signal output.
P2-4	Alarm 2 transistor open collector output.
P2-5	Alarm 3 transistor open collector output.
P2-6	Alarm 4 transistor open collector output.
P2-7	Selected units pulse output (used for calibration).
P2-8	+5V logic supply
P2-9	Return ground connection: alarm transistor external supply and/or battery back-up ground.
P2-10	Low pin disables EEPROM storage of changed parameters.
P2-11	Low pin initiates a serial printout; V01 command (COMMAND mode: "BUS.5=1").
P2-12	TTL-level Test RX
P2-13	TTL-level Test TX
P2-14	Meter digital ground (Internally connected to P2-9).
P2-15	Not connected.
P2-16	Not connected.
P2-17	External CALIBRATION lockout jumper. If you install S2A, connect a jumper from P2-17 to P2-18 to allow for calibration.
P2-18	
P2-19	Not connected.
P2-20	External Back-up battery +V terminal.

SECTION 9. SYNCHRONIZING THE INTERNAL REAL TIME CLOCK

You may synchronize the internal Real Time clock 2 different ways:

- * From the line frequency (50Hz or 60Hz, most accurate).
- * From the internal crystal time-base (less accurate).

Configuration byte #2 allows you to select between these two options.

"CF2.5=0" for line frequency
"CF2.5=1" for internal crystal time-base.

Under normal conditions we recommend you use line frequency synchronization, the factory default. It is the most accurate way to keep constant time because the power company adjusts the 60Hz or 50Hz line frequency each night to keep errors to a minimum. If your meter is in an environment which is subject to a lot of ac line noise, select the internal crystal frequency.

SECTION 10. CALIBRATING THE METER

CALIBRATION PROCEDURE

Note: Only qualified personnel, with accurate test equipment, should calibrate the meter.

1. Install jumper S2-A to enable calibration factor modification.
2. Connect P2-17 to P2-18 externally.
3. Attach a 6-digit period counter to P2 pin 7 (Pulse output), with return lead to P2 pin 14. This is a TTL level pulse output (Transistor-Transistor Logic - 0 to 5 Vdc).

Note: Meter must be able to measure periods of 1200 mSec or greater.

4. Configure the meter for the "MM MM.MM" (99 99.99) .01 min resolution timebase.
5. Press the **MENU** button until "CALIB" displays.
6. Press the **STOP** button to display the current calibration factor. The period counter should now display a number close to 1200.00 mSEC. If the number on the period counter is higher than 1200.00, decrease the calibration factor ("CALIB" more negative). If the period counter is lower than 1200.00 increase the calibration factor ("CALIB" more positive).
7. Change the "CALIB" number until the period counter value is between 1199.96 and 1200.04 (+/- 0.003%).

Enter a calibration factor number between -127 and +127.

CALIBRATION PROCEDURE (Continued)

8. Allow a few seconds for the reading to settle after you change the "CALIB" number. When you change the display, changes affect meter calibration immediately, therefore the "CALIB" number should change the value on the period counter. After calibration, press **MENU** to store the new value.
9. Remove the jumper between P2-17 and P2-18 (to ensure you do not change the CALIB value again). If you want to protect the meter from accidentally changing the CALIB factor, remove the jumper from S2-A. This will prevent any internal calibration change. Once you remove S2-A from the main board, no calibration is allowed.

SECTION 11. REVIEWING THE METER'S INTERNAL SETTINGS

In the **RUN** mode, press the **REVIEW** button to check the current internal settings of the timer, determine current cycle number and/or verify stop value. During this review the unit continues its timing cycle and control functions.

The meter flashes the menu item name for about 2 seconds and the associated value with a non-flashing display for about 3 seconds. The meter scrolls through all applicable menu items and values.

If the meter is set up for the Real Time clock, the **REVIEW** button displays only the date, year and battery condition because other information in the review table is not applicable.

Serial communication is not possible during meter REVIEW.

DISPLAY1: (flashing)	DISPLAY2: (non-flashing)	DESCRIPTION:
CNT UP (CNT DN)	(no display)	Count direction
START	0000 10	Timer START value
STOP	000 34	Timer STOP value
CYC LN	F00002	CYCLE limit value
CU CYC	00254 1	Current CYCLE value
UNITS	MMMS	Timer units selected
LIMVAL	999999	Limit values for units selected
DATE	PPR 06	Meter calendar DATE
YR 1992	(no display)	Meter calendar YEAR
BAT OK (BAT LO)	(no display)	When battery back-up board is installed, signals the status of the batteries.

Note: The non-flashing values are for example purposes only.

SECTION 12. CONFIGURING TIMER UNITS

A timer unit is a measure of time. Real Time units display as a digital clock (12-hour for conventional time and 24-hour for military style time). Other timer units display according to what resolution you set up and when that timer unit becomes active. To configure the meter to use **one** of eight different timer units, follow these steps:

1. Press the **MENU** button until "UNITS" appear.
2. Press the **STOP** button to display the current timer unit.
3. Press the **STOP** button to scroll through available timer units.
4. Press the **MENU** button to store.

#	Maximum Values:	Timer Units:	Notes:
1	992359	DDHHMM	1 min resolution
2	125959	HHMMSS	12 hr Real Time Clock (count up only!)
	235959		24 hr Real Time Clock (count up only!)
3	995959	HHMMSS	1 sec resolution
4	995999	MMSSSS	.01 sec resolution
5	999999	HHHHHH	1 hr resolution
6	999999	HHHHHH	.01 hr resolution
7	999999	MMMMMM	.01 min resolution
8	999999	SSSSSS	.01 sec resolution

Timer

Units: D = Days
 H = Hours
 M = Minutes
 S = Seconds

SECTION 12. CONFIGURING TIMER UNITS (Continued)

You have 2 choices for a Real Time clock: a 12-hour format with AM and PM LED indication or a 24-hour clock without AM/PM indicators.

A 12-hour clock the meter displays time in the following format:

12.00.00 -> 11.59.59 AM
 12.00.00 -> 11.59.59 PM

Note: *If you do not select a Real Time clock as the timebase, the meter internally updates real time and date function.*

SECTION 13. SELECTING TIMER CONTROL

Timer units other than the Real Time clock have stopwatch and time control functionality. The meter has two input control selections using the rear connectors P9 and P3:

To select external control (at the rear of the meter) set configuration bit "CF2.1=1". If you select external control, the **STOP** button does not start and stop the timer - however, the **STOP** button still configures other functions. To use the **STOP** button to start and stop the timer, **and** configure other functions, set configuration bit "CF2.1=0".

For Both 2 and 3-Wire Control:

The START timer (TB9-1) is a negative edge triggered input.
The STOP timer (TB9-2) is a negative edge triggered input.
The RESET timer (TB9-3 and TB3-2) is a negative true level input.
The ON timer (TB3-1) is a negative true level input.

13.1 3-WIRE CONTROL: START, STOP and RESET

If you select 3-wire control the timer starts upon the first encountered negative edge, or negative level change at the START input. Timer then stops on the first encountered negative edge or negative level change at the STOP input. The meter pre-sets to the timer start value if the RESET input is held low. You need 4 wires if you require remote RESET.

13.2 2-WIRE CONTROL: ON (run gate) and RESET

If you select 2-wire control the timer starts when the ON input is held low, or grounded to TB3 pin 3. The timer stops when the ON input is released or held high. The ON input is internally pulled up to +5V, and defaults the timer to the OFF condition. You need 3 wires if you require remote RESET.

13.3 LOGIC INPUT INFORMATION FOR 2 AND 3-WIRE CONTROL:

All logic inputs require a minimum pulse width of 10 milliseconds.

The combination of the START, STOP, RESET inputs and the 4 ON/OFF outputs allow these operating modes;

- * **Alarm Clock** - capable of controlling up to 4 loads at specific times of day.
- * **Reset Timer** - single-cycle timer or stopwatch with control outputs at pre-set times.
- * **Repeat Cycle Timer** - control cycles up to 999,999.
- * **Sequence Controller** - controls up to 4 loads, such as a camshaft, camswitch timer, or stepswitch timer.

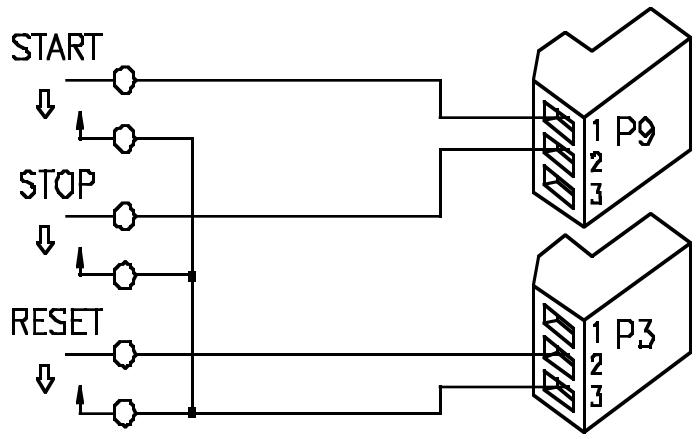

Figure 13-1. 3-Wire Timer Control

13.3 LOGIC INPUT INFORMATION FOR 2 AND 3-WIRE CONTROL (Continued)

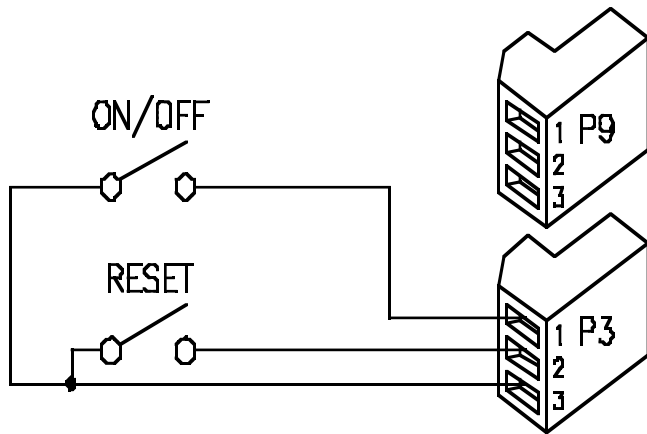

Figure 13-2. 2-Wire Timer Control

SECTION 14. CONFIGURING CONTROLLER OUTPUT MODES

You may configure the meter's 8 setpoints for 1 of the 5 following output control modes:

Non-Pattern Modes:

- * Independent ("INDEP")
- * Elapse ("ELAPSE")
- * Pause ("PAUSE")

Pattern Modes:

- * Independent Pattern ("INDPAT")
- * Ganged Pattern ("GANPAT")

To configure a CONTROLLER OUTPUT mode:

1. Access "SP OPT" (a main menu item).
2. Press the **STOP** button. The current mode appears.
3. Continue to press the **STOP** button to scroll through **CONTROLLER OUTPUT** modes.
4. Once correct **CONTROLLER OUTPUT** appears, press the **MENU** button to store the value.

14.1 NON-PATTERN MODES

14.1.1 Independent Mode ("INDEP")

In this mode the timer starts with all outputs in the "OFF" state. Also, for the 4 outputs, all odd setpoints (SP1,3,5,7) are the "ON" times and all even setpoints (SP2,4,6,8) are the "OFF" times. For example, if SP1=0010.52 and SP2=0051.24, output 1 is "ON" **between** 10.52 and 51.24 and "OFF" during any other time.

If you configure the unit for the 12-hour Real Time clock, you may configure each setpoint to be active for AM or PM.

To Enter AM/PM Setup for Setpoint Configurations:

You must select "HH.MM.SS" for the units (Real Time 12-hour clock), and either the Independent setpoint ("INDEP") mode or Independent Pattern setpoint ("INDPAT") mode to access AM/PM.

14.1.1 Independent Mode ("INDEP") (Continued)

1. Press the **SETPTS** button once to momentarily flash "STPT 1", then display the actual value for setpoint #1. Setpoint 1 appears, with left-most digit flashing.
2. Press the **REVIEW** button to change the digit's value and the **STOP** button to move horizontally through the display.
3. Once correct numeric value appears, press the **STOP** button to access "AM/PM" on the front-panel display.
4. Press the **REVIEW** button to toggle between AM and PM.
5. Once correct abbreviation appears, press the **SETPTS** button to store new setpoint values.

Note: *Once you store the setpoint value the meter advances to the next setpoint.*

6. If you wish to return to the **RUN** mode, press the **RESET** button.
Note: *If you press the **SETPTS** button and do not press any other button for about 20 seconds, the meter automatically switches into the **RUN** mode.*

The setpoint range must be within the same day or 24-hour period. In other words, the high or even setpoint may not exceed 11.59.59PM if the low or odd setpoint is below 11.59.59PM.

14.1.1 Independent Mode (Continued)

For example, you select SP1 = 05.00.00PM and SP2 = 12.01.00AM

This is an illegal configuration because SP2 is in reality lower than SP1 (one minute after midnight). The meter converts the 12-hour clock setpoints when in the **INDEP** mode to 24-hour format. Therefore, 12.01.00AM becomes 00.01.00 in **24-HOUR** mode and lower than SP1 which is set up for 05.00.00PM or 17.00.00 in 24-hour format. Use the 24-hour clock when AM and PM setpoints overlap.

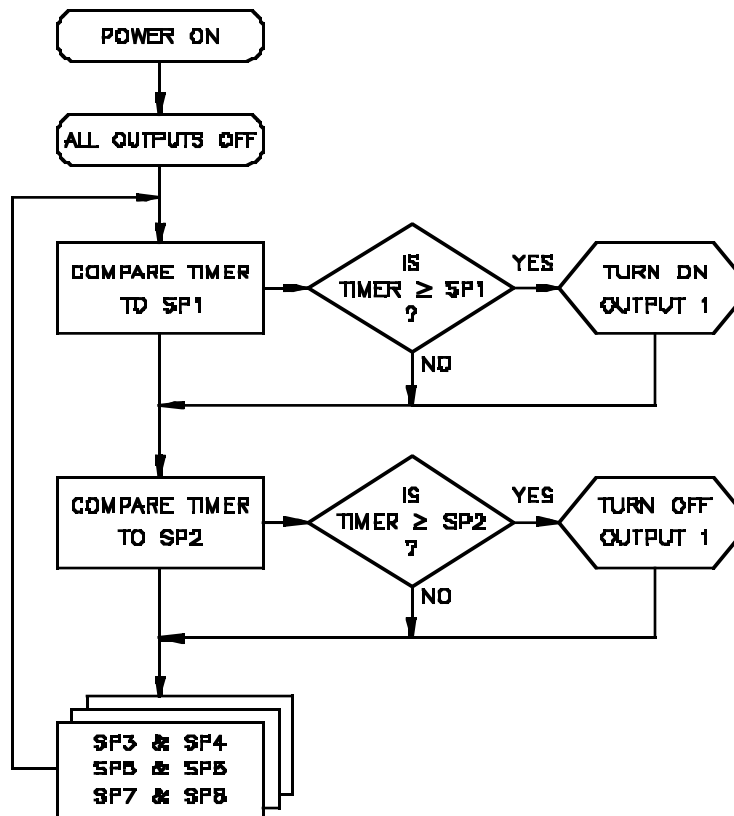

Figure 14-1. INDEP Mode Flowchart

14.1.1 Independent Mode (Continued)

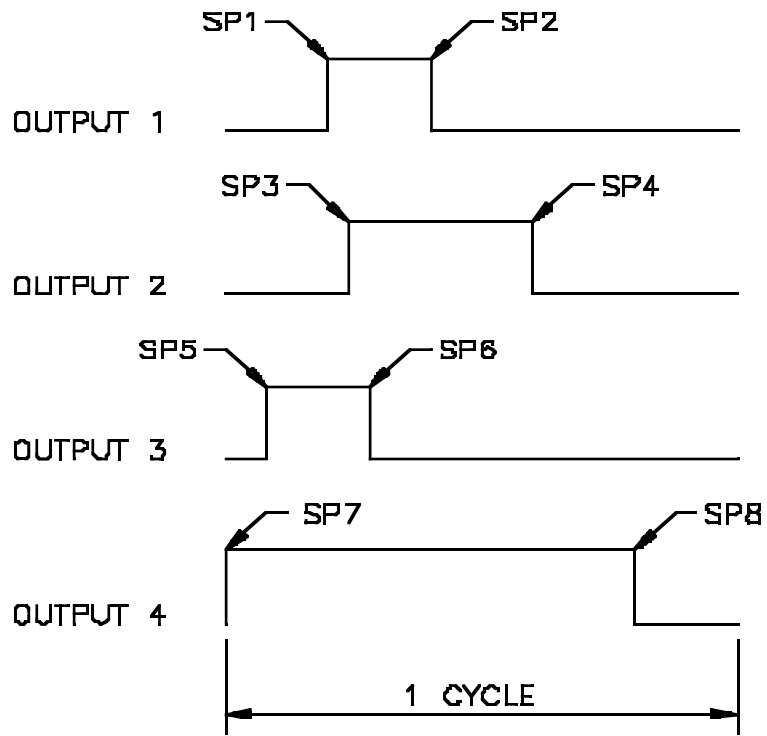

Figure 14-2. INDEP Setpoint Illustration

14.1.2 Elapse Mode (ELAPSE)

In this mode all odd setpoints (SP1,3,5,7) are the "TURN-ON" times for the four outputs, and all even setpoints (SP2,4,6,8) represent the outputs "ON" time, or "ELAPSED ON TIME".

For example, you select a MM:SS.SS timebase (one second resolution -99:59.99), SP1=0010.52 and SP2=0051.24 and count up direction. Output 1 is therefore on **between** 10.52 and 1.01.76 (SP1+SP2). Count down direction results in an SP1-SP2 equation. The Elapsed time depends on what timer units you select.

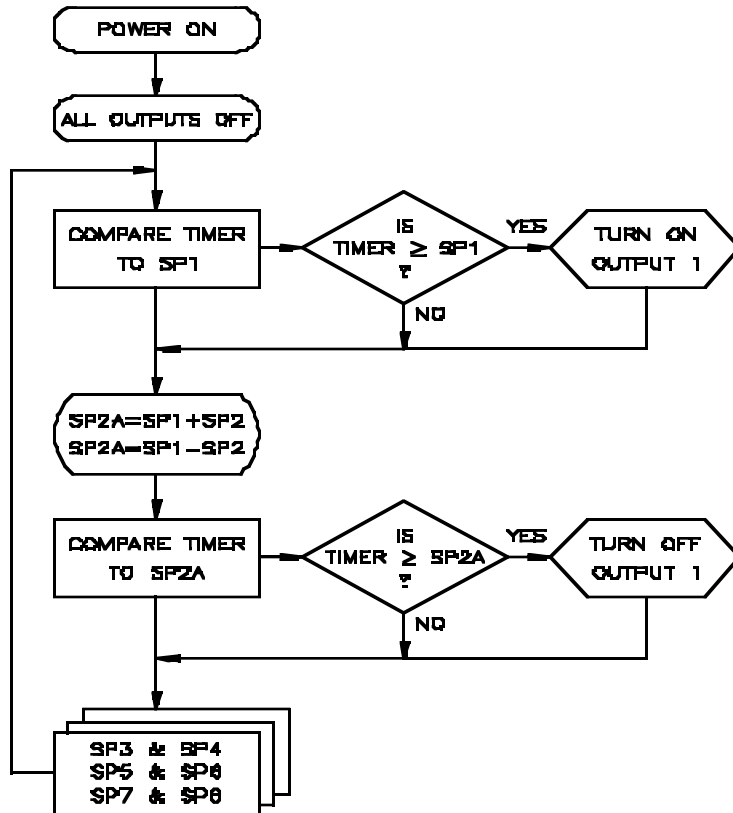

Figure 14-3. ELAPSE Mode Flowchart

14.1.2 Elapse Mode (ELAPSE) (Continued)

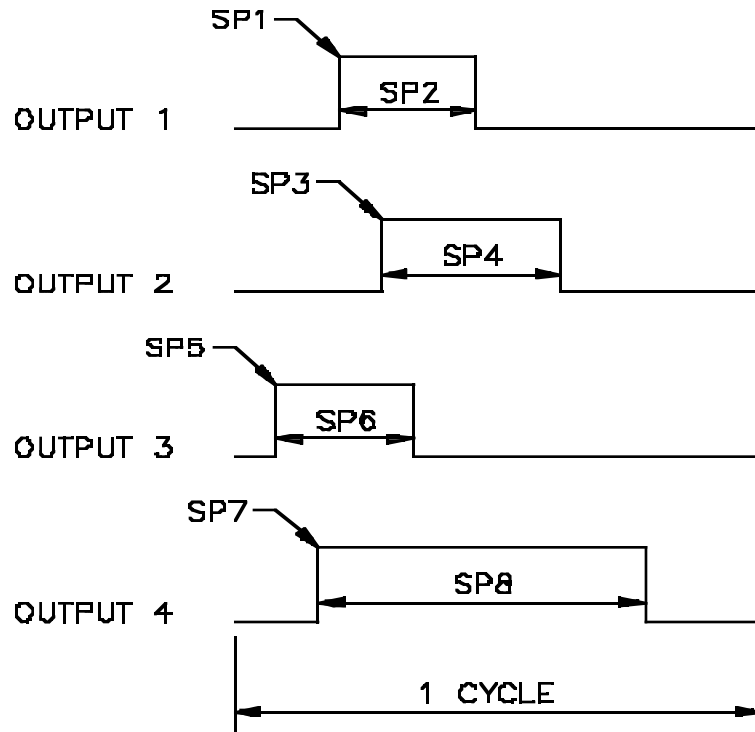

Figure 14-4. ELAPSE Setpoint Illustration

14.1.3 Pause Mode (PAUSE)

In this mode all odd setpoints (SP1,3,5,7) represent the "TURN-OFF" times for the 4 outputs, and all even setpoints (SP2,4,6,8) represent the outputs "OFF" time or "PAUSED-OFF" time. **PAUSE** mode functions the opposite of the **ELAPSE** mode. For example, you select a MM:SS.SS timebase (one second resolution - 99:59.99), SP1=0010.52 and SP2=0051.24 and count up direction. Output 1 is therefore off **between** 10.52 and 1.01.76 (SP1+SP2) Count down direction results in an SP1-SP2 equation. The Paused time depends on what timer units you select.

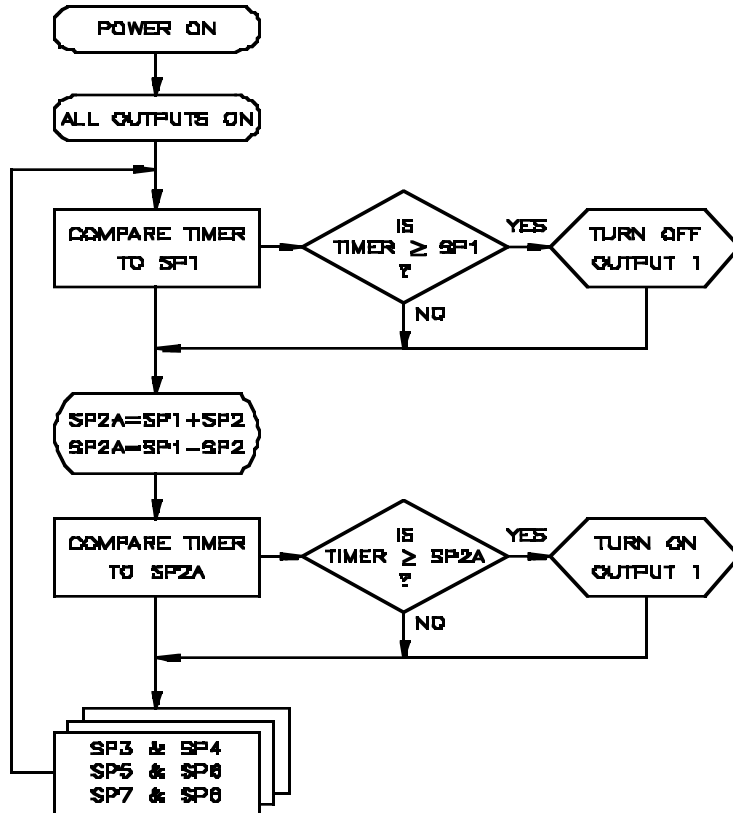

Figure 14-5. PAUSE Mode Flowchart

14.1.3 Pause Mode (PAUSE) (Continued)

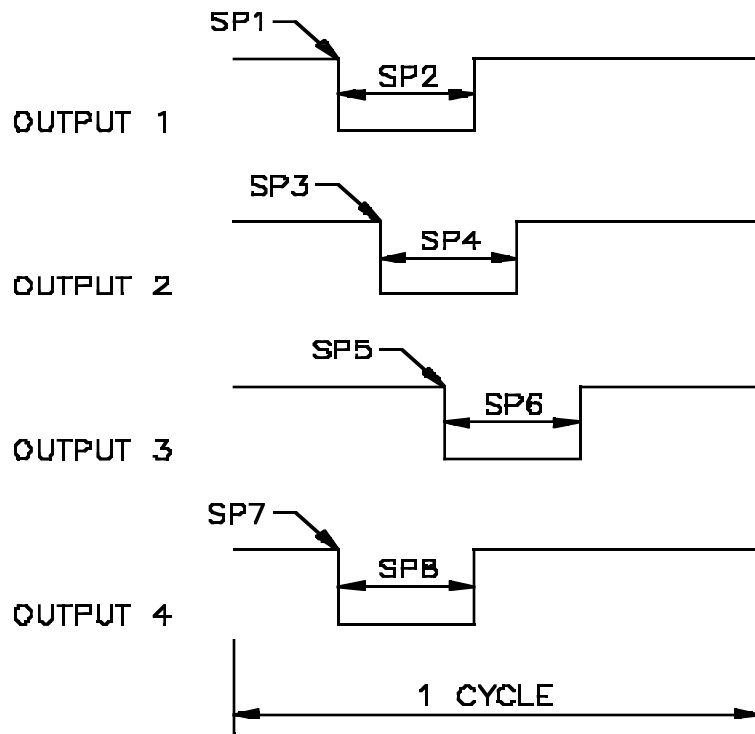

Figure 14-6. PAUSE Setpoint Illustration

14.1.4 Door Control Example

This section uses a door control example to detail 2 different output control modes: **INDEP** and **ELAPSE**.

In this example you want to control the opening time periods for a set of doors in a factory. You have 4 doors at different sides of the building which need to open at different times during a 24-hour period.

Table 14-1. Door Control Example Description

1.

Door #	Description	Control Times:	
		Open	Closed
Door 1	Main Entry	8:30 AM	5:00 PM
Door 2	Receiving	8:30 AM	3:30 PM
Door 3	Night Shift	5:00 PM	11:30 PM
Door 4	Cafeteria	11:30 AM	2:45 PM

T h e

Independent output control mode requires the following setpoint configurations to open and close the doors according to the times in Table 14-1.

Note: *The Independent output control mode recognizes all odd setpoints as "ON" times and all even setpoints as "OFF" times. For example, Table 14-2 sets up door #1 to be open between 8:30 AM and 5:00 PM.*

14.1.4 Door Control Example (Continued)

Table 14-2. Door Control Example
Independent Output Control Mode

Door #	Setpoint #	Setpoint Time
1	1	08.30.00 AM
1	2	05.00.00 PM
2	3	08.30.00 AM
2	4	03.30.00 PM
3	5	05.00.00 PM
3	6	11.30.00 PM
4	7	11.30.00 AM
4	8	02.45.00 PM

The following needs to be set up prior to configuring the Independent output control mode:

- * 12-hour Real Time clock (with correct time)
- * UNITS = HH:MM:SS
- * SP OPT = INDEP

Once all setpoint values are entered, pressing the **RESET** button twice starts the control process.

2. The Elapsed output control mode requires the following setpoint configurations to open and close the doors according to the times in Table 14-1.

Note: The equations for the Elapsed output control mode are $SP1+SP2$, $SP3+SP4$, $SP5+SP6$ and $SP7+SP8$ (if you select count down direction, the equations is $SP1-SP2$, etc.).

14.1.4 Door Control Example (Continued)

**Table 14-3. Door Control Example
Elapsed Output Control Mode**

Door #	Setpoint #	Setpoint Time
1	1	08.30.00
1	2	08.30.00
2	3	08.30.00
2	4	07.00.00
3	5	17.00.00
3	6	06.30.00
4	7	11.30.00
4	8	03.15.00

The following needs to be set up prior to configuring the Elapse output control mode:

- * 24-hour clock (with correct time)
- * UNITS = HH:MM:SS
- * SP OPT = ELAPSE

Once all setpoint values are entered, pressing the **RESET** button twice begins the control process.

When meter applications require accurate and **constant** time keeping, the optional battery back-up plug-in board keeps the time running in case of a power failure. Call our sales department to order the battery back-up plug-in board.

Refer to Section 19, Battery Back-Up Board, for more information on battery back-up.

14.2 PATTERN CONTROL

You may set up your meter to pre-configured patterns on the outputs. A pattern is "the output condition of all four outputs" For example, the pattern for all outputs OFF is 0000, the pattern for all outputs ON is 1111. The pattern for Alarm 1 ON and Alarm 2, 3 and 4 OFF is 1000, etc. You may have the meter put several of these patterns onto the control outputs within a count range cycle.

Two control modes use these patterns:

1. Independent Pattern mode (**INDPAT**)
2. Ganged Pattern mode (**GANPAT**)

A pattern group consists of 8 patterns. The meter may store 8 pattern groups for popular control setups, and easy recall of more complex control applications. The meter may store a total of 64 patterns.

If your application requires each output to go through several "ON-OFF" cycles during one controller timer "range of count cycle", you may use the independent pattern or ganged pattern setpoint mode to accomplish this.

14.2.1 Independent Pattern Mode (INDPAT)

In this mode all outputs start in the "OFF" state. When the meter encounters setpoint 1 ("SP1"), Pattern 1 is active for outputs 1 through 4. When meter encounters setpoint 2 ("SP2"), Pattern 2 is active for outputs 1 through 4, and so forth (refer to Table 14-4). Setpoints 1 through 8 are the start times of patterns 1 through 8 respectively. The timer uses the 8 patterns from the selected group with the P.G.SEL menu item. If you configure the meter for the 12-hour Real Time clock, you may configure each setpoint to be active for AM or PM.

The **INDPAT** mode has the following advantages:

1. Each output may go through several "ON-OFF" cycles during one controller timer range of counts cycle.

14.2.1 Independent Pattern Mode (INDPAT) (Continued)

2. Easy maintenance of the output switch patterns while changing individual setpoint times.
3. Easy change of output switch control patterns while maintaining the individual setpoint times.

To Enter AM/PM Setup for Setpoint Configurations:

You must select "HH.MM.SS" for the units (Real Time 12-hour clock), and either the Independent setpoint (**INDEP**) mode or Independent Pattern setpoint (**INDPAT**) mode to access AM/PM.

1. Press the **SETPTS** button once to momentarily flash "STPT 1", then display the actual value for setpoint #1. Setpoint 1 appears with the left-most digit flashing.
2. Press the **REVIEW** button to change the digit's value and the **STOP** button to move horizontally through the display.
3. Once the correct numeric value displays, press the **STOP** button to access the AM/PM on the front-panel display.
4. Press the **REVIEW** button to toggle between AM/PM.
5. Once correct abbreviation appears, press the **SETPTS** button to store new setpoint values.

Note: *Once you store the setpoint value the meter advances to the next setpoint.*

6. If you wish to return to the **RUN** mode, press the **RESET** button.

Note: *If you press the SETPTS button and do not press any other button for about 20 seconds, the meter automatically switches into the RUN mode.*

The setpoint range must be within the same day or 24-hour period. In other words, the high or even setpoint may not exceed 11.59.59PM if the low or odd setpoint is below 11.59.59PM.

14.2.1 Independent Pattern Mode (INDPAT) (Continued)

Table 14-4 Setpoint/Pattern Relationship

If Timer Reaches	Pattern # On Output:
SP1	PAT # 1
SP2	PAT # 2
SP3	PAT # 3
SP4	PAT # 4
SP5	PAT # 5
SP6	PAT # 6
SP7	PAT # 7
SP8	PAT # 8

Note: You may configure setpoint out of sequential order.

CAUTION: ASSIGN A DIFFERENT VALUE TO EACH SETPOINT. IF YOU ASSIGN THE SAME VALUE TO MORE THAN ONE SETPOINT YOU CONFUSE THE METER. THIS CONFUSION RESULTS IN ERRATIC ALARM OUTPUTS WHEN THE TIMER REACHES THE IDENTICAL VALUE.

14.2.1 Independent Pattern Mode (INDPAT) (Continued)

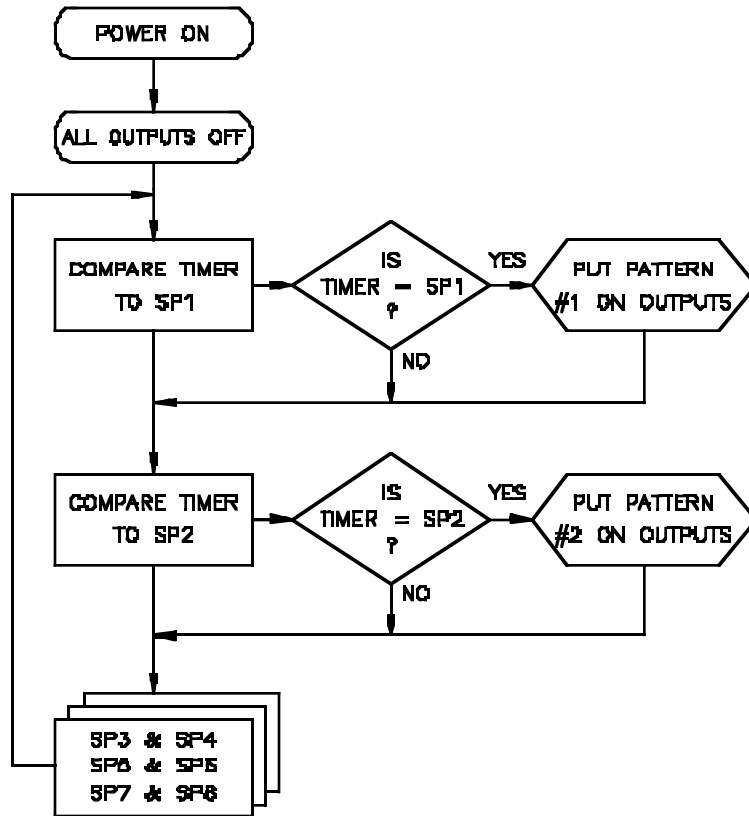

Figure 14-7. INDPAT Mode Flowchart

14.2.1 Independent Pattern Mode (INDPAT) (Continued)

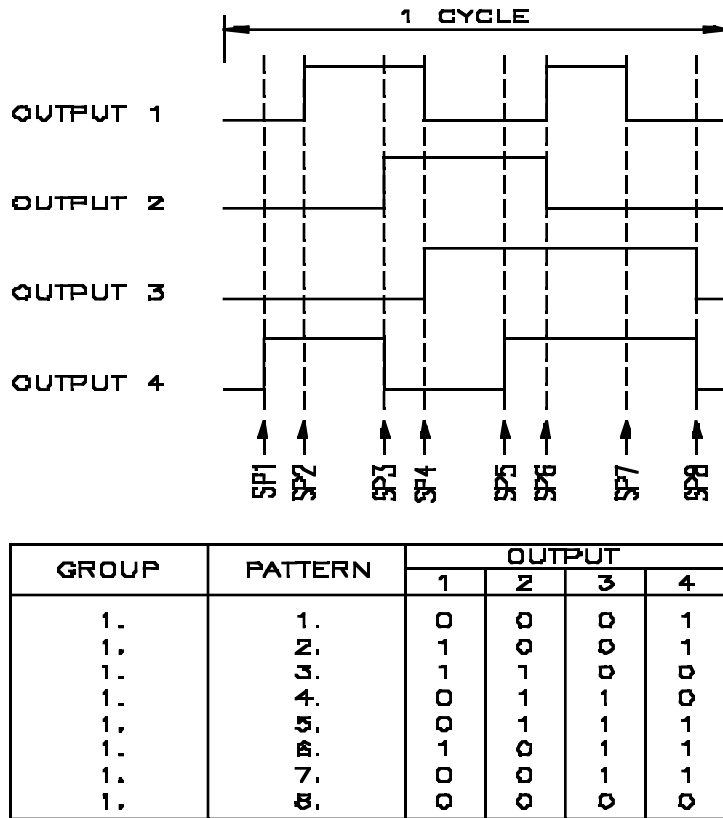

Figure 14-8. INDPAT Setpoint Illustration

14.2.2 INDPAT Mode Example

Table 14-5 shows all output states between Power-Up and SP1 are in the "OFF" condition because the meter sets all outputs to the OFF condition until it encounters the first setpoint. In the **INDPAT** mode, setpoints 1 through 8 are the start times for patterns 1 through 8 respectively. The example illustrated in Tables 14-6 and 14-7 require the following settings:

SP OPT = INDPAT

UNITS = HH:MM:SS with max value of 12.59.59 (time of day clock)

Table 14-5. INDPAT Mode Example

Time Period		Output states for This Time Period			
Start	Finish	1	2	3	4
Power-Up	9:00AM	OFF	OFF	OFF	OFF
9:00AM	9:30AM	ON	ON	ON	ON
9:30AM	10:45AM	OFF	OFF	ON	ON
10:45AM	12:30PM	ON	OFF	OFF	ON
12:30PM	1:00PM	OFF	ON	OFF	OFF
1:00PM	4:00PM	ON	ON	ON	OFF
4:00PM	5:00PM	OFF	OFF	OFF	ON
5:00PM	6:30PM	ON	ON	OFF	ON
6:30PM	9:00AM	OFF	OFF	OFF	ON

Table 14-6 shows the setpoint inputs and output switch pattern inputs for this application.

14.2.2 INDPAT Mode Example (Continued)

Table 14-6. INDPAT Mode Example

Time Period		Output states for This Time Period				
Setpoint	Setpoint Input	Output Switch Pattern Input	1	2	3	2
SP1	09.00.00 AM	1.1.1111	1	1	1	1
SP2	09.30.00 AM	1.2.0011	0	0	1	1
SP3	10.45.00 AM	1.3.1001	1	0	0	1
SP4	12.30.00 PM	1.4.0100	0	1	0	0
SP5	01.00.00 PM	1.5.1110	1	1	1	0
SP6	04.00.00 PM	1.6.0001	0	0	0	1
SP7	05.00.00 PM	1.7.1101	1	1	0	1
SP8	06.30.00 PM	1.8.0001	0	0	0	1

14.2.3 Ganged Pattern Mode (GANPAT)

In this mode all outputs start in the "OFF" state. When the meter encounters setpoint 1 (SP1), Pattern 1 is active for outputs 1 through 4. Pattern 1 is active (ON) for the output time equal to SP1+SP2 (SP1-SP2 in the **COUNT DOWN** mode). The "OFF" time of Pattern 1 is the start time of Pattern 2, and is active for output time equal to SP2+SP3. (SP2-SP3 in the **COUNT DOWN** mode). You may pre-program a total of 8 ganged patterns, as illustrated in Table 14-7.

14.2.3 Ganged Pattern Mode (GANPAT) (Continued)

Table 14-7. Ganged Pattern Description

If Timer Reaches:	Pattern # on Output:
SP1	PAT # 1
COUNT UP (COUNT DOWN)	
SP1+SP2 (SP1-SP2)	PAT # 2
SP2+SP3 (SP2-SP3)	PAT # 3
SP3+SP4 (SP3-SP4)	PAT # 4
SP4+SP5 (SP4-SP5)	PAT # 5
SP5+SP6 (SP5-SP6)	PAT # 6
SP6+SP7 (SP6-SP7)	PAT # 7
SP7+SP8 (SP7-SP8)	PAT # 8

The **GANPAT** mode operates in a sequential manner. The effective setpoint value of PAT # 2 should be higher (lower when counting down) than the effective value of PAT # 1, the effective setpoint value of PAT # 3 should be higher (lower when counting down) than the effective setpoint value of PAT # 2, etc.

14.2.2 Ganged Pattern Mode (GANPAT) (Continued)

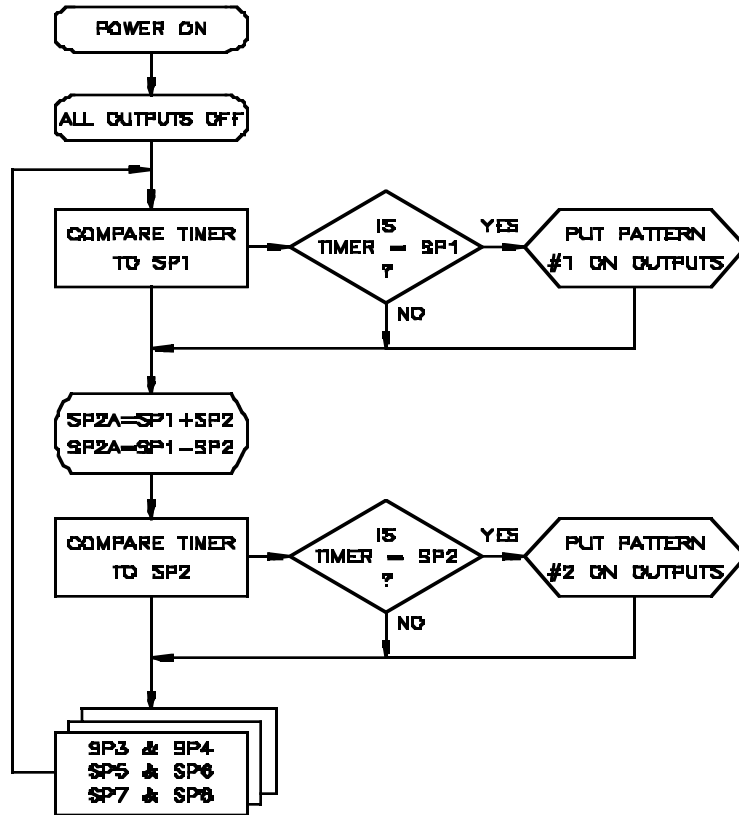

Figure 14-9. GANPAT Mode Flowchart

14.2.4 Cycle Testing

You may turn 4 loads on and off using the open collector outputs or optional relay board. You may wire START/STOP/RESET inputs to start the cycle remotely, and if problems occur during the testing, stop externally. Use the output patterns to obtain control variations. If an external control line stops the timer, push the **REVIEW** button to display the meter's setup. **REVIEW** also displays the cycle number the meter was executing prior to being stopped. When the meter finishes its programmed cycles the display switches to indicate the Real Time clock.

14.2.5 Pattern Group "Edit" Programming Example

This example instructs you how to edit stored pattern groups. This example sets up your meter to use the **INDPAT** mode of operation and programs (configures) Group # 4.

1. Press the **MENU** button until the meter displays "UNITS". Press the **STOP** button to scroll through available timebases. Once "MMMM.MM" appears, press the **MENU** button to store your selection. The meter then displays "SP OPT" (Setpoint Option).
2. Press the **STOP** button to scroll through setpoint options until the meter displays "INDPAT". Press the **MENU** button to store your selection. The meter displays "P.G. SEL" (Pattern Group Selection).
3. Press the **STOP** button. The meter displays "P.RP= x" (x = 1 through 8). Press the **STOP** or **REVIEW** button to scroll through pattern group numbers until "P.GRP= 4" appears. Press the **MENU** button to store the value.
4. Press the **MENU** button until the meter displays "P.G.EDIT" (Pattern Group Edit). You may view and edit all 8 groups. Press the **STOP** button. The meter displays "GRP= 1". Press the **STOP** button to scroll through pattern group edit numbers until "GRP= 4" appears.
5. Press the **STOP** button until the meter displays "GRP=4", then press the **MENU** button. A flashing display similar to the following appears:
"4.1.xxxx"

Note :x represents the output states of alarm1 through alarm4 (left to right, respectively).

6. Press the **REVIEW** button. The second digit from the left flashes. This is the pattern number. Press the **REVIEW** button again to scroll through all eight (8) available patterns in this group 4 (the xxxx values change from 0 to 1's according to previous input).

When the meter displays "4.1.xxxx", press the **STOP** button to access alarm values. Set up alarm values as follows:

4.10001	4.20010
4.30011	4.40100
4.50101	4.60110
4.70111	4.81000

Press the **REVIEW** button to toggle display values between 0 to 1 and the **STOP** button to scroll through alarms. 0=OFF and 1=ON. Once pattern information is correct, press the **MENU** button to store. Meter displays "GRP= 1".

14.2.5 Pattern Group "Edit" Programming Example (Continued)

7. Press the **RESET** button. Set "START" at "000000", "STOP" at "000010", "CYCLE" at "000010", count up direction and Setpoints 1 - 8 at 1 - 8 (respectively). Refer to Section 4 (Configuring the Meter) if you need additional information regarding setup of these options.
8. To edit or view another group, press the **STOP** button to display another group.
9. After you complete steps 1 -9 you are finished with this example and ready to run the meter using the **INDPAT** mode. As the unit runs, the display counts up from zero to 00.00.10. The output LEDs 1 through 4 light up according to the alarms configured in step 7. Setpoints and cycle (10 times) will be according to information entered in step 7.

14.2.6 Fall-Back Pattern

A fall-back pattern is a safety precaution, and causes all 4 alarm outputs to enter into a pre-configured state for emergency situations. The meter's default fall-back pattern turns the 4 open-collector transistor outputs OFF (nonconducting -FB.0000). You may change this fall-back pattern to any pattern. The meter stores the fall-back pattern in the EEprom memory.

Enable the fall-back pattern by setting "CF2.3=0".

Disable the fall-back pattern by setting "CF2.3=1".

If "CF2.3=0", any one of the following actions activates the fall-back pattern:

- * Pressing the **STOP** button if the meter is in the **RUN** mode (freezes all of the meters actions except for the internal Real Time clock, calendar, and the serial communication port).
- * Pressing the **MENU** button if the meter in the **RUN** mode (**MENU** mode is anytime you press the **MENU** button).
- * Pressing the **SETPTS** button to view or modify the setpoints.

SECTION 15. INTERFACING SERIAL COMMUNICATIONS

The Isolated Serial RS-232 Communications Board provides an isolated digital communications channel between a single meter and another meter or device, or between a single meter and a computer.

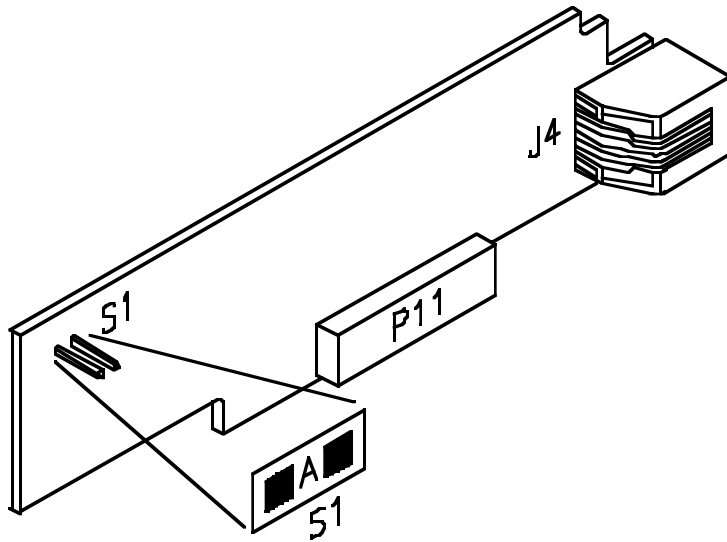

Figure 15-1. RS-232 Serial Communications Board

SERIAL COMMUNICATIONS (Continued)

The Isolated Serial RS-485 Communications Board adheres to the IEC standard and therefore provides an isolated channel between a single computer (or intelligent device) and up to 32 meters—actually a choice of 199 different devices.

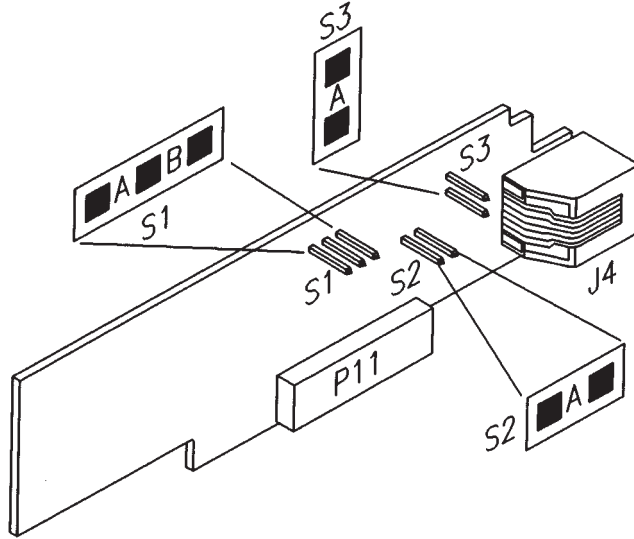

Figure 15-2. RS-485 Serial Communications Board

15.1 SERIAL COMMUNICATION SPECIFICATIONS

RS-232

Baud Rates	300, 600, 1200, 2400,4800, 9600, and 19,200
Connection	RJ-12, 6-wire telephone jack, data in, data out, RTS, GND
Transmit Capability	Programmable to send TIMER display, Real Time, ALARM status, DATE, START, STOP, CYCLE values
Receive Capability	Set up via front-panel configuration

RS-485

Baud Rates	300, 600,1200, 2400,4800, 9600, and 19,200
Connection	RJ-12, 6-wire telephone jack, full or half-duplex.
Transmit Capability	Programmable to send TIMER display, Real Time, ALARM status, DATE, START, STOP, CYCLE values, Special RS-485 CONTROLLER mode
Receive Capability	Set up via front-panel configuration
Addressing	1 to 199

15.2 RS-232 HARDWARE

The RS-232 card is approximately 11" high and 5" long. Remove the meter from its case before installation. P11 inserts into J-11 (a row of pins located on the main board, next to the transformer). The board is held in position by a plastic guide on the rear of the display board and plastic assembly at the rear of the meter. The 6-pin telephone jack, J4, is at the rear of the meter case and accepts a type RJ-11 or RJ-12 telephone plug.

Logic signals are opto-isolated. Meter obtains drive power from a galvanically-isolated transformer winding. You may slave the $_7V$ signal levels from the meter to the external controller (computer) ground; earthing that ground is recommended.

Figure 15-3 illustrates four-wire RS-232 connections between the host computer/controller and the meter (point-to-point full-duplex, with RTS handshake).

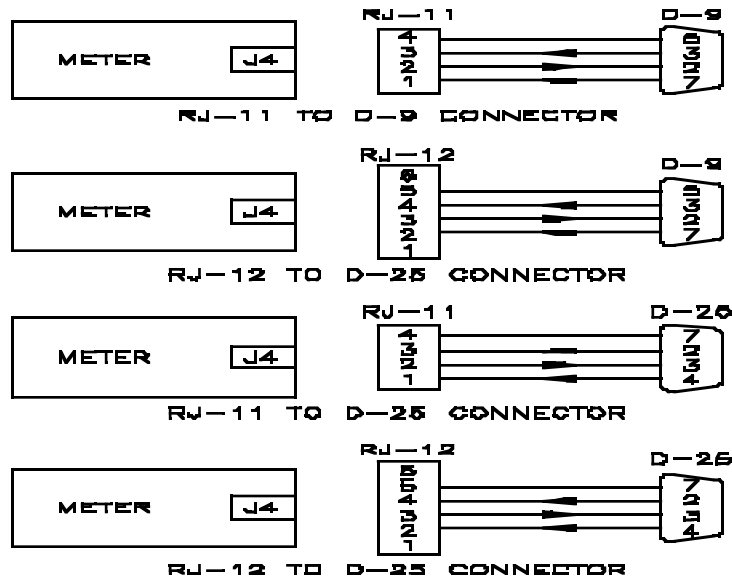

Figure 15-3. 4-Wire RS-232 Connections

15.2 RS-232 HARDWARE (Continued)

You may connect an RJ-11 or RJ-12 telephone jack to a computer. The computer may use a 9 or 25 pin "D" connector. Refer to Table 15-1 for detail information.

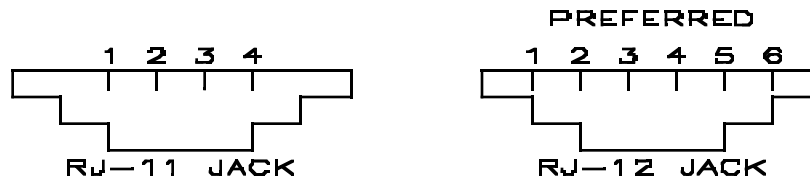

Figure 15-4. RJ-11 and RJ-12 Connectors

Table 15-1. Telephone Jack to Computer Hookup Information

Pin Signal/Function	Meter (DCE)		Computer (DTE)	
	RJ-11	RJ-12	D9	D25
RTS meter from computer	1	2	7	4
TX, meter = RX, computer	2	3	2	3
RX, meter = TX, computer	3	4	3	2
GND	4	5	5	7
NC (not connected)	-	1 & 6	(all others)	

15.2 RS-232 HARDWARE (Continued)

Table 15-2. Telephone Jack to Printer Hookup Information

Pin Signal/Function	Meter		Printer Function
	RJ-11	RJ-12	
RTS meter	1	2	Data Terminal Ready (DTR)
TX, meter	2	3	Received Data (RXD)
RX, meter	3	4	Not connected
GND	4	5	Signal Ground
NC (not connected)	-	1 & 6	

15.3 RS-485 HARDWARE

The RS-485 card is the same size as the RS-232 card (approximately 11" high and 5" long). The RS-485 card plugs in the same way as the RS-232 card, however, there are 4 jumper-selected features.

The S1-A jumper adjusts for half-duplex (a channel with bidirectional data flow, but only in one direction at a time)

The S1-B jumper allows for full-duplex (two channels with bidirectional data flow at any time).

The S2 jumper adds an impedance-matching 121 Ohms across half-duplex lines.

The S3 jumper impedance-matches the other pair of wires for full-duplex lines.

15.3 RS-485 HARDWARE (Continued)

Logic symbols are opto-isolated. The meter obtains drive power from a galvanically-isolated transformer winding, therefore the differential signals (minimum 2V) are not altered by an external ground; earthing of the external transceiver power supply is recommended to limit **COMMON**-mode voltage.

You may operate the RS-485 hardware point-to-point (e.g. as RS-422 equipment), or in multi-point, sharing the bus wires with up to 30 other meters.

The RS-485 cabling may be a single pair of wires (usually with a shield) for half-duplex, or two such pairs for full-duplex. Figure 15-5 illustrates bus operation, with tap-offs for each meter.

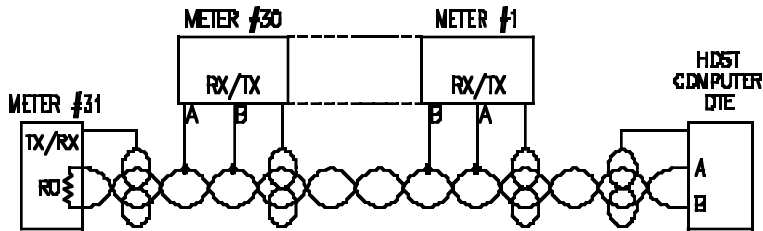

Figure 15-5. Multi-Point Half-Duplex RS-485 Connection

Table 15-3. Half-Duplex Hookup to the Computer

Pin Signal/Function	Meter (DCE)	Computer (DTE)
	RJ-12	D9/D25
A, RX/TX	1	(SEE MFG DWG)
B, RX/TX	2	(SEE MFG DWG)
GND	3	(See MFG DWG)

15.3 RS-485 HARDWARE (Continued)

RS-422/RS-485 multi-point interconnections between the computer (DTE) and the meter (DCE) are less well-defined because different computer/controller manufacturers use different pins on their D9 or D25 connectors.

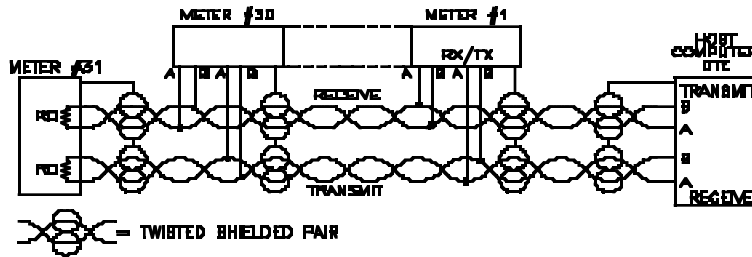

Figure 15-6. Multi-Point Full-Duplex RS-485 Connection

Table 15-4. Full-Duplex Hookup to the Computer

Pin Signal/Function	Meter (DCE)	Computer (DTE)
	RJ-12	D9/D25
ATX = +TX	1	(SEE MFG DWG)
BTX = -TX	2	(SEE MFG DWG)
ARX = +RX	4	(SEE MFG DWG)
BRX = -RX	5	(SEE MFG DWG)
GND	3	(SEE MFG DWG)
NC (Not Connected)	6	

Both half-duplex and full-duplex RS-485 communications require that you connect a 6-wire RJ-12 plug to the RJ-12 jack at the rear of the meter.

15.3 RS-485 HARDWARE (Continued)

A standard has not been established for the D9 or D25 connector pin-out for RS-485. Please refer to your computer or controller manual to ensure the correct cable connections.

Note: *If communication with your meter has failed, check the receive portion of the RS-485 board on DTE (Computer). These lines should be pulled up for +RX and pulled down for -RX with resistors, with a resistance value from 330 Ohms to 1k Ohms.*

15.4 SENDING COMMANDS

CAUTION: ENTER ALL COMMUNICATION COMMANDS USING UPPERCASE LETTERS. THE METER DOES NOT RECOGNIZE LOWERCASE COMMANDS.

15.4.1 Communication Classes

There are 3 communication classes:

- * **POINT-TO-POINT** mode (direct connection between two devices)
- * **MULTI-POINT** mode (shared wiring, a bus, between numerous devices and a single computer)
- * **RS-485 CONTROLLER** mode (**MULTI-POINT** mode with timer as controller)

The meter uses ten or eleven bits for each character: a start bit, **seven bits for the ASCII character**, one parity bit and either one or two stop bits. If the parity bit is chosen as "none", the meter automatically sets the stop bit at two bits (to keep the minimum character length to ten bits).

15.4.1 Communication Classes (Continued)

POINT-TO-POINT communication has two modes:

- * **CONTINUOUS** (a message from the meter is sent at intervals set by the SER TI choice (or when a print request through P2-11 is enabled). Often used for data logging when a hard copy of certain meter readings is needed at specific intervals.
- * **COMMAND** (no message is sent until a command is received). Often used when direct communication with, or control over, the meter is necessary.

MULTI-POINT mode communication only has **COMMAND** mode.

RS-485 CONTROLLER mode is useful for datalogging other meters on a RS-485 bus. People who need datalogging features, but do not have a computer to control the datalogging process may find the RS-485 useful (refer to Section 15.15, **RS-485 CONTROLLER** Mode).

15.4.2. Command Types

**CAUTION: DAT FT AND BUS FT MUST BE SET CORRECTLY
ACCORDING TO YOUR SETUP BEFORE YOU GIVE ANY
COMMANDS TO THE METER.**

The meter responds to 6 command groups:

1. R (Read) - Read data from EEPROM (nonvolatile memory)
G (Get) - Read data from RAM (operating memory)
2. X - Read decimal format Timer values
V - Read decimal format Timer data string
3. U - return status character data from the meter

15.4.2. Command Types (Continued)

4. P (Put) - Write data to RAM (operating memory)
W (Write) - Write data to EEPROM (nonvolatile memory)
5. D (Disable), E (Enable), and Z (Reset) disable, enable, and reset meter features or conditions
6. ^AE - Read communications parameters (does not require the recognition character)

15.4.3 Command Formats

Point-to-Point command formats:

P (Put) and W (Write):

*ccc<data>[hh]<CR>

G, R, X, U, V, D, E, and Z:

*ccc[hh]<CR>

15.4.4 Point-to-Point Format Explanation

Example: *ccc<data>[hh]<CR>

The first character, * (the asterisk), is the Recognition Character. The asterisk is the default, but you can use any character in the ASCII table from "<SP>" (hex 20) to "DEL" (hex 7D). With the exception of: "^", "A", "E"

The second set of characters is ccc. ccc designates the Command Class and the Command Suffix. Command class and suffix identify the type of command and the meter feature, or parameter, to which it is directed.

15.4.4 Point-to-Point Format Explanation (Continued)

The third set of characters is <data>. <data> designates the string of characters with the variable information the computer is sending to the meter.

The fourth set of characters is [hh]. [hh] designates the optional checksum parameter (Square brackets always enclose optional parameters).

15.4.5 Multi-Point Format Explanation

Multi-point command format is identical to that of Point-to-Point with the addition of the meter address (designated by nn) after the Recognition character:

*nnccc[<data>][hh]<CR> or *nnccc[hh]<CR>

15.4.6 HEX ASCII Format

DATA is sometimes sent to or received from the meter in the HEX ASCII format. This format allows control of each bit. One byte consists of 8 bits. One nibble consists of 4 bits, therefore one byte consists of two nibbles. Table 15-5 is a conversion table for binary bits (1 nibble) and their HEX ASCII equivalents.

15.4.6 HEX ASCII Format (Continued)

Table 15-5. HEX ASCII Conversion Information

Binary Bits:	Hex Equivalent:
0 0 0 0	0
0 0 0 1	1
0 0 1 0	2
0 0 1 1	3
0 1 0 0	4
0 1 0 1	5
0 1 1 0	6
0 1 1 1	7
1 0 0 0	8
1 0 0 1	9
1 0 1 0	A
1 0 1 1	B
1 1 0 0	C
1 1 0 1	D
1 1 1 0	E
1 1 1 1	F

15.5 SERIAL COMMUNICATION MENU ITEMS

To access serial communication menu items, do the following:

1. Press the **MENU** button until "SERSET" appears.
2. Press the **STOP** button to access the serial communications menu items. "BAUD" appears.

The meter displays serial communication menu items in the following order:

- "BAUD" (baud rate)
- "SERCNF" (serial configuration)
- "DAT FT" (data format)
- "BUS FT" (BUS format)
- "SER AD" (serial device address)
- "SER TI" (serial time)

Use serial communication in the **RUN** mode only. Serial communications is not possible during **MENU** or **SETPOINT** mode, or when **REVIEW** is in process. Install S1-A to disable the front-panel pushbuttons and insure that communication with the meter is not disturbed. If you select a baud rate lower than 9600 and use this baud rate with a .01 second timebase, display update rate is significantly reduced. Select higher baud rates (9600 or 19200) for communicating with the meter when using .01 second timebases.

15.5.1 BAUD (Baud Rate)

Baud Rate is the first menu item to appear after you follow steps 1 and 2 above.

1. Press the **STOP** button to display the currently used baud rate.

15.5.1 BAUD (Baud Rate) (Continued)

2. Press the **REVIEW** button to scroll through the following baud rate options:

- * "300"
- * "600"
- * "1200"
- * "2400"
- * "4800"
- * "9600"
- * "19200"

3. Press the **MENU** button to store your selection.

15.5.2 SERCNF (Serial Configuration)

The meter displays Serial Configuration after Baud Rate.

1. Press the **STOP** button to display currently used options.
2. Press the **REVIEW** button to toggle serial configuration values between 0 and 1.
3. Press the **STOP** button to scroll through the following serial configuration options:

- "SER.1=0" - No parity
- "SER.1=1" - Odd parity
- "SER.1=2" - Even parity

- "SER.2=0" - One stop bit
- "SER.2=1" - Two stop bits

4. Press the **MENU** button to store your selection.

15.5.3 DAT FT (Data Format)

The meter displays Data Format after Serial Configuration.

1. Press the **STOP** button to display currently used options.
2. Press the **REVIEW** button to toggle data format values between 0 and 1.
3. Press the **STOP** button to scroll through the data format options, as listed in Table 15-6.
4. Press the **MENU** button to store your selection.

Table 15-6. Data Format Options

"DAT.1 = "	0 = Alarm status excluded 1 = Alarm status included
"DAT.2 = "	0 = Current cycle value excluded 1 = Current cycle value included
"DAT.3 = "	0 = Timer display value excluded 1 = Timer display value included
"DAT.4 = "	0 = Start value excluded 1 = Start value included
"DAT.5 = "	0 = Stop value excluded 1 = Stop value included
"DAT.6 = "	0 = Total Cycle value excluded 1 = Total Cycle value included
"DAT.7 = "	0 = Real Time excluded 1 = Real Time included
"DAT.8 = "	0 = Date excluded 1 = Date included

Factory default settings are bold.

15.5.4 BUS FT (BUS format)

The meter displays BUS Format after Data Format.

1. Press the **STOP** button to display currently used options.
2. Press the **REVIEW** button to toggle BUS Format values between 0 and 1.
3. Press the **STOP** button to scroll through the data format options, as listed in Table 15-7.
4. Press the **MENU** button to store your selection.

Table 15-7. BUS Format Options

"BUS.1="	0 = Checksum excluded 1 = Checksum included
"BUS.2="	0 = Linefeed with response <LF> excluded 1 = Linefeed with response <LF> included
"BUS.3="	0 = Echo response excluded 1 = Echo response included
"BUS.4="	0 = POINT-TO-POINT mode 1 = MULTI-POINT mode (RS-485 only)
"BUS.5="	0 = If point-to-point; CONTINUOUS mode 1 = If point-to-point; COMMAND mode
"BUS.6="	0 = Message handshake 1 = Character handshake
"BUS.7="	0 = RS-485 board OFF 1 = RS-485 board ON
"BUS.8="	0 = <SPACE> separator for bits 1-8 of DATA FRMT 1 = <CR> separator for bits 1-8 of DATA FRMT

Factory default settings are bold

15.5.5 SER AD (RS-485 Serial Device Address)

The meter displays the Serial Device Address after Bus Format.

1. Press the **STOP** button to display currently address.
2. Press the **REVIEW** button to change the value of the flashing digit. If you continue to press the **REVIEW** button, the flashing digit's value continues to change.
3. Press the **STOP** button to scroll to the next digit.
Note: You may enter any value from 000 to 199 for the device address.
4. Press the **MENU** button to store your selection.

15.5.6 SER TI (Serial Time)

The meter displays Serial Time after Serial Device Address. You must have BUS.5=0 (**CONTINUOUS** mode) for this item to be functional.

1. Press the **STOP** button to display current seconds between V01 transmissions.
2. Press the **REVIEW** button to change the value of the flashing digit. If you continue to press the **REVIEW** button, the flashing digit's value continues to change.
Note: You may enter any value from 000000 to 999999. This allows up to 11.57 days of delay between V01 transmissions.
(999999 x 1 sec = 11.57 days)
3. Press the **STOP** button to scroll to the next digit.
4. Press the **MENU** button to store your selection.

15.6 SERIAL COMMUNICATION COMMAND STRUCTURE

15.6.1 Command Class Letter Abbreviations

Table 15-8. Command Class Letters

Reviewing the timer's internal settings	11	Reviewing the Timer's Internal Settings
Selecting a timer unit	12	Configuring Timer Units
Selecting 2 or 3 wire timer control	13	Selecting Timer Control
Setting up non-pattern (independent; elapse; pause) & pattern modes (independent; ganged); Configuring AM/PM setpoints; setting up a fall-back pattern	14	Configuring Controller Output Modes
RS-232/RS 485/Communication classes/point to point mode/multi-point mode/phone jack hook-up information, command types/formats/Hex ASCII format	15	Interfacing Serial Communications
Isolated parallel BCD output board. specifications, jumper functions, PS assignments, enabling transmission of BCD data; multiplex, board address	16	Isolated Parallel BCD Output Board
Dual relay output board: specifications; jumper functions	17	Dual Relay Output Board
Four relay output board: specifications; jumper functions	18	Four Relay Output Board
Installing a battery back-up board	19	Attaching a Battery Back-Up Board

15.6.2 Single Commands

Single commands provide quick response and/or control of the meter.

Table 15-9. Single Commands

Command	Suffix	Item Effected	#chars
D	01	Select COUNT DOWN mode	0
E	01	Select COUNT UP mode	0
U	01	Alarm status	1
V	02	Transfer pre-aligned message	2(X)
X	01	Read current display value	6*
Z	01	Reset from panel RESET emulation	0
D	02	Select 12 HOUR CLOCK mode	0
E	02	Select 24 HOUR CLOCK mode	0
X	02	Read timer START value	6*
Z	02	Reset Panel reset from EEPROM	0
X	03	Read timer STOP value	6*
D	04	STOP timer (STOP button emulation)	0+
E	04	START timer (STOP button emulation)	0+
X	04	Read CURRENT CYCLE value	6
D	05	50% display brightness	0
E	05	100% display brightness	0

* string length from meter may be 6 to 8 char depending on UNITS selected.

(x) "V01" response length determined by the "DAT FT" and "BUS FT" configurations.

(+) = Command only allowed when front panel START/STOP has been selected (CFG2.1=0).

15.7 COMMAND SUFFIXES

The two hex characters following the command class letter specify the effected controller data, features or menu items. Table 15-10 details the command letter, suffix, effected feature and the number of data characters included in the command.

Table 15-10. Command Suffixes

Command	Suffix	Item Effected	#Chars
G.P.R.W	01	SETPNT COMPARE modes	2
G.P.R.W	02	Time: START value	6*
G.P.R.W	03	Time: STOP value	6*
G.P.R.W	04	Time: CYCLE value	6
G.P.R.W	05	Times selected	2
G	06	Current CYCLE value	6
G.P	07	Res. Time value (HEMMSS)	3
G.P	08	DATE (MMDDYYYY)	8
G.P.R.W	09	SP1, Setpoint #1 value	6*
G.P.R.W	0A	SP2, Setpoint #2 value	6*
G.P.R.W	0B	SP3, Setpoint #3 value	6*
G.P.R.W	0C	SP4, Setpoint #4 value	6*
G.P.R.W	0D	SP5, Setpoint #5 value	6*
G.P.R.W	0E	SP6, Setpoint #6 value	6*
G.P.R.W	0F	SP7, Setpoint #7 value	6*
G.P.R.W	10	SP8, Setpoint #8 value	6*
R.W	11	CNFG1, Configuration byte #1	2
G.P.R.W	12	SRCONF, communications configuration	2

Table 15-10. Command Suffixes (Continued)

Command	Suffix	Item Effected	#Chars
G,P,R,W	13	DATA FT, communications DATA FORMAT	2
G,P,R,W	14	BUS FT, communications BUS FORMAT	2
G,P,R,W	15	MISC/HTS, misc/Parasitic control bits	2
G,P,R,W	16	CALIBR, calibration factor (-1/120)	2
G,P,R,W	17	ADDRESS, RS 485 device # address	2
R,P,R,W	18	Serial recognized char (20h - 7Fh)	2
G,P,R,W	19	Currently used pattern group	2
R,W	1A	PAT1, Pattern Group #1	8
R,W	1B	PAT2, Pattern Group #2	8
R,W	1C	PAT3, Pattern Group #3	8
R,W	1D	PAT4, Pattern Group #4	8
R,W	1E	PAT5, Pattern Group #5	8
R,W	1F	PAT6, Pattern Group #6	8
R,W	20	PAT7, Pattern Group #7	8
R,W	21	PAT8, Pattern Group #8	8
G,P,R,W	22	FALLBACK, Fallback pattern	2
G,P,R,W	23	CONFIG, Configuration byte #2	2
G,P,R,W	24	SER TT, # of seconds print spacing	6
G,P,R,W	25	SERDELAY, Serial command delay	2
G,P,R,W	26	ANALOG Serpoint configuration (17 bit)	2

* string length from meter with "G", and "R" commands may be from 6 to 8 char depending on UNITS selected.

15.8 SERIAL PARAMETER VALUES

Note: All examples assume POINT-TO-POINT mode and the "*" (asterisks) for the recognition character.

15.8.1 Suffix: "01"

Command Classes Abbreviations: G,P,R,W
Comments:
Setpoint compare modes: 01 = INDEP
02 = ELAPSE
04 = PAUSE
08 = INDPAT
10 = GANPAT

*Example: "*P0108" = set compare mode for INDPAT*

15.8.2 Suffix: "02"

Command Classes Abbreviations: G,P,R,W
Comments: Timer START value is any legal value within the limits set by the UNITS selected.

*Example: "*P02000745" = set START value to 000745*

15.8.3 Suffix: "03"

Command Classes Abbreviations: G,P,R,W
Comments: Timer STOP value is any legal value within the limits set by the UNITS selected.

*Example: "*P03013260" = set STOP value to 013260*

15.8 SERIAL PARAMETER VALUES (Continued)

15.8.4 Suffix: "04"

Command Classes Abbreviations: G,P,R,W

Comments: Timer CYCLE value is any number from 000001 through 999999. To cycle forever place an 'F' in most significant digit position. (F00000)

*Example: ****P04000989** = set CYCLE value to 000989*

*****P04F00989** = set to CYCLE forever*

15.8.5. Suffix: "05"

Command Classes Abbreviations: G,P,R,W

Comments:

To select the timer UNITS:

01 = DD.HH.MM	99.23.59
02 = HH.MM.SS	Real Time clock
03 = HH.MM.SS	99.59.59
04 = MM.SS.SS	99.59.99
05 = HH HH HH	999999
06 = HH HH.HH	9999.99
07 = MM MM.MM	9999.99
08 = SS SS.SS	9999.99

Legend: D = Days
H = Hours
M = Minutes
S = Seconds

*Example: ****P0507** = set timer for UNITS: MM MM.MM with limit values of 99 99.99*

15.8 SERIAL PARAMETER VALUES (Continued)

15.8.6 Suffix: "06"

Command Classes Abbreviation: G

Comments: To GET the current CYCLE value from RAM. "G" is the only valid command for this suffix/abbreviation combination.

*Example: "**G06" gets the current CYCLE value.*

15.8.7 Suffix: "07"

Command Classes Abbreviations: G,P

Comments: To GET or PUT the time of day to/from RAM: The "P" command requires the 24-hour format for setting the time to RAM because the internal clock uses 24-hour format only. Enter any legal time value within the **24-HOUR CLOCK** mode.

*Example: "**P07160000" = 4 o'clock PM*

*"**P07041532" = 4:15AM and 32 seconds*

15.8.8 Suffix: "08"

Command Classes Abbreviations: G,P

Comments: To read and set the DATE, from/to RAM. Enter any legal date with the following format:

"MMDDYY"

(M = month, D = day, Y = year)

You may enter any year between **1990 and 2053**.

*Example: "**P0805021999" = May 2, 1999*

15.8 SERIAL PARAMETER VALUES (Continued)

15.8.9 Suffix: "09", "0A", "0B", "0C", "0D", "0E", "0F", "10"

Command Classes Abbreviations: G,P,R,W

Comments: To set the value of setpoints 1,2,3,4,5,6,7 and 8, respectively.
Enter any legal value within the limits set by the UNITS selected.

*Example: "*P0B013260" = set SP3 value to 013260*

15.8.10 Suffix: "11"

Command Classes Abbreviations: R,W

Comments: To set configuration byte #1. The configuration byte #1 consists of one byte (8 bits):

CF1.1 - bit 0 of configuration #1

CF1.8 - bit 7 of configuration #1

Refer to Table 5-1 for more information on configuration menu items.

*Example: "*W110A" =* *Enable display and setting of setpoint values.*
 Disable display and setting of serial
communication parameters.

Enable display & setting of all menu items.

Disable EEPROM storage.

No BCD board installed.

100% display brightness.

RS-485 CONTROLLER mode disabled.

15.8 SERIAL PARAMETER VALUES (Continued)

15.8.11 Suffix: "12"

Command Classes Abbreviations: G,P,R,W

Comments: To set the serial configuration byte (2 characters - 2 nibbles of data).

Bit Pattern	Selects Baud Rate
3 2 1 0	
0 0 0 0	300
0 0 0 1	600
0 0 1 0	1200
0 0 1 1	2400
0 1 0 0	4800
0 1 0 1	9600
0 1 1 0	19200

Bit Pattern	Selects
7 6 5 4	
0 0 0 0	No parity*
0 0 0 1	Odd parity
0 0 1 0	Even parity
0 0 x x	One stop bit
0 1 x x	Two stop bits

* Automatically resets to 2 stop bits, by the meter to get ten-bit characters.

*Example: "*P1256" sets the meter up for 19200 baud with two stopbits and odd parity.*

15.8 SERIAL PARAMETER VALUES (Continued)

15.8.12 Suffix: "13"

Command Classes Abbreviations: G,P,R,W

Comments: To set the DAT format. The DAT format consists of one byte (8 bits) if:

DAT.1 - bit 0 of Data format

DAT.8 - bit 7 of Data format

These two nibbles determine how the meter responds to the "V01" command. Refer to Table 15-6 for more information on data format options.

*Example: "*P1314" sends the Timer value and Stop value on a V01 request.*

15.8.13 Suffix: "14"

Command Classes Abbreviations: G,P,R,W

Comments: To set the BUS format. The BUS format consists of one byte (8 bits) if:

BUS.1 - bit 0 of BUS format

BUS.8 - bit 7 of BUS format

These two nibbles determine how the meter's hardware operates. Refer to Table 15-7 for more information on BUS format options. **This command does not allow you to set the unit up for CONTINUOUS mode!**

*Example: "*P1414" echoes the response and puts the meter in **COMMAND** mode*

15.8 SERIAL PARAMETER VALUES (Continued)

15.8.14 Suffix: "15"

Command Classes Abbreviations: G,P,R,W

Comments: To set the miscellaneous control byte (2 characters/ nibbles)

Bit Pattern	Selects
3 2 1 0	
x x x 0	Count up
x x x 1	Count down
x x 0 x	3 wire control
x x 1 x	2 wire control
x 0 x x	12-hour clock
x 1 x x	24-hour clock
0 x x x	AM 12-hour clock *
1 x x x	PM 12-hour clock *

* = Do not program AM or PM with these 2 bits. The meter automatically selects AM/PM when you program the time using command:"P07".

15.8.15 Suffix: "16"

Command Classes Abbreviations: G,P,R,W

Comments: To set the calibration factor. You may program the calibration factor via the serial communication link **only** if S2-A jumper is installed and P2-17 is connected to P2-18. If the jumper is not installed the meter will respond with error message code **?4C**.

The calibration factor is a value within the range of +/- 127. This number fits nicely inside one byte, with the 8th bit representing the polarity. Bits 1 through 7 may represent any value from 0 to 127. Bit 8 allows the meter to accept a value as a negative number.

*Example: "**P168A" is a calibration factor of -10.*

15.8 SERIAL PARAMETER VALUES (Continued)

15.8.16 Suffix: "17"

Command Classes Abbreviations: G,P,R,W

Comments: To set the serial address. The serial address is the device number the meter uses when you install an RS-485 communications board. You may enter a number from 1 through 199 using hexadecimal entry.

*Example: "**P17C6" sets the device address for 198.*

15.8.17 Suffix: "18"

Command Classes Abbreviations: G,P,R,W

Comments: To view and change the serial recognition character. This is the security code letter for all of the commands except for the ^AE command. Enter a valid character address are from 21h to 7Fh with the exception of "^","A","E" characters.

*Example: "**P1821" makes the recognition character "!".*

15.8.18 Suffix: "19"

Command Classes Abbreviations: R,W

Comments: To configure a stored pattern group if you have the setpoint mode set to **INDPAT** or **GANPAT**.

01 = pattern group #1

05 = pattern group #5

02 = pattern group #2

06 = pattern group #6

03 = pattern group #3

07 = pattern group #7

04 = pattern group #4

08 = pattern group #8

*Example: "**W1905" uses the stored pattern group #5.*

15.8 SERIAL PARAMETER VALUES (Continued)

15.8.20 Suffix: "22"

Command Classes Abbreviations: G,P,R,W

Comments: To Set the Fall-back pattern. The Least significant nibble pattern controls the four outputs.

Example: "*P2205" sets the Fall-back pattern to 1001:

output 1 = On

2 = Off

3 = Off

4 = Off

15.8.21 Suffix: "23"

Command Classes Abbreviations: G,P,R,W

Comments: To set configuration byte #2. Refer to Table 5-2 for more information on configuration menu items. The configuration byte #2 consists of one byte (8 bits) if:

CF2.1 - bit 0 of configuration #2

CF2.3 - bit 2 of configuration #2

Example: "*P2381" enables external Start/Stop control and the **RS-485 CONTROLLER** mode.

15.8.22 Suffix: "24"

Command Classes Abbreviations: G,P,R,W

Comments: To set the delay time in seconds between "V01" transmissions. Use this number to control how many times information is sent to a remote serial printer or terminal device (set BUS.5=0).

Example: "*P24000128" meter waits 128 seconds between continuous transmissions.

15.8 SERIAL PARAMETER VALUES (Continued)

15.8.23 Suffix: "25"

Command Classes Abbreviations: G,P,R,W

Comments: To set the serial delay used on half-duplex systems (e.g., RS-485), not on full-duplex (RS-232 or RS-422). This turnaround delay is useful in eliminating the effects of ringing, reflections or line drops.

MSN	LSN	Milliseconds of Turnaround Delay
0	0	0
0	1	30
0	2	100
0	3	300

*Example: "*P2502" will set the turnaround delay for 100ms*

15.8.24 Suffix: "26"

Command Classes Abbreviations: G,P,R,W

Comments: If you select a **12-HOUR CLOCK** and the **INDEP** or **INDPAT** mode, this parameter value controls the configurations for each of the setpoints.

Example "P262F" sets the setpoints accordingly:

Value of	SP1 = PM	Value of	SP5 = AM
" "	SP2 = PM	" "	SP6 = PM
" "	SP3 = PM	" "	SP7 = AM
" "	SP4 = PM	" "	SP8 = AM

CAUTION: ONLY WRITE AM/PM SETPOINT CONFIGURATIONS WHEN YOU SELECT THE INDEP OR INDPAT MODE WITH THE 12-HOUR REAL TIME CLOCK. WRITING VALUES TO THIS LOCATION ANY OTHER TIME EFFECTS THE CYCLE VALUE.

15.8 SERIAL PARAMETER VALUES (Continued)

15.8.24 Suffix: "26" (Continued)

Command Classes Abbreviations: G,P,R,W

Bit Pattern	Selects
3 2 1 0	
x x x 0	SP #1 = AM
x x x 1	SP #1 = PM
x x 0 x	SP #2 = AM
x x 1 x	SP #2 = PM
x 0 x x	SP #3 = AM
x 1 x x	SP #3 = PM
0 x x x	SP #4 = AM
1 x x x	SP #4 = PM

Bit Pattern	Selects
7 6 5 4	
x x x 0	SP #5 = AM
x x x 1	SP #5 = PM
x x 0 x	SP #6 = AM
x x 1 x	SP #6 = PM
x 0 x x	SP #7 = AM
x 1 x x	SP #7 = PM
0 x x x	SP #8 = AM
1 x x x	SP #8 = PM

15.9 METER RESET THROUGH SERIAL COMMUNICATIONS

"Z01" emulates the front panel reset button. "Z02" is a bit more powerful: after the meter receives the "Z02" command it re-boots the meter and re-loads all of the data retained in the non-volatile memory into active memory.

15.10 STATUS CHARACTER FORMATS

If the meter receives a "U01" command it transmits an alarm status character. Table 15-11 illustrates the transmitted character for each of the 16 possible alarm states.

Table 15-11. Character/Alarm States

Character	AL#1	AL#2	AL#3	AL#4
Q	OFF	OFF	OFF	OFF
A	ON	OFF	OFF	OFF
B	OFF	ON	OFF	OFF
C	ON	ON	OFF	OFF
D	OFF	OFF	ON	OFF
E	ON	OFF	ON	OFF
F	OFF	ON	ON	OFF
G	ON	ON	ON	OFF
H	OFF	OFF	OFF	ON
I	ON	OFF	OFF	ON
J	OFF	ON	OFF	ON
K	ON	ON	OFF	ON
L	OFF	OFF	ON	ON
M	ON	OFF	ON	ON
N	OFF	ON	ON	ON
O	ON	ON	ON	ON

15.11 "^AE" RESPONSE FORMAT

When you enter "^AE" (caret AE) 4 bytes of data display, (8 hex-ASCII characters), followed by a carriage return.

Example: 2AC70156.

These 4 bytes break down as follows (refer to the above example while reading through these definitions):

- 1: Serial recognition character: "*" sent as ASCII "2A".
- 2: Device address: "199" sent as ASCII "C7".
- 3: Bus format byte: 01.
- 4: Serial configuration byte: 19200 Baud, Odd parity, 2 stopbits sent as ASCII "56".

15.12 METER COMMUNICATION IN THE CONTINUOUS MODE

If the meter is in **POINT-TO-POINT CONTINUOUS** mode, it ignores any transmitting command. To stop **POINT-TO-POINT CONTINUOUS** mode, transmit "X-OFF" character (13 Hex, 19 Decimal), equivalent to RTS line false. Transmit "X-ON" character (11 Hex, 17 Decimal) to resume **POINT-TO-POINT CONTINUOUS** mode (RTS line true). Specifically, if you transmit the command "^AE" the meter switches to **COMMAND** mode.

15.12 METER COMMUNICATION IN THE CONTINUOUS MODE (Continued)

To communicate with the meter in **CONTINUOUS** mode, complete the following steps:

1. Transmit "X-OFF" character (make "RTS" line false).
2. Transmit "^AE" command (enter **COMMAND** mode).
3. Transmit "X-ON" character (make "RTS" line true).
4. Communicate with meter.

15.12.1 "V01" Response Data Format

The "V01" command is the meter's workhorse command. It can be setup to send pre-configured messages. Once the meter receives a "V01" command all of the items set to 1 in DATA FORMAT display will be transmitted (refer to Table 15-6, Data Format Options, for more information).

Message length varies, depending on "DAT FT" Data Format and "BUS FT" Bus Format.

15.13 EXTERNAL PRINT COMMAND

To enable the external print function, temporarily ground pin 11 of the "P2" rear connector. This causes the meter to transmit a "V01" response. External printing is only valid in the **POINT-TO-POINT COMMAND** mode.

15.14 SERIAL COMMUNICATIONS ERROR MESSAGES

Table 15-12. Serial Communications Error Messages

Error message	Code	Possible Cause(s)
Command	253	Command prefix or suffix error.
Format	4n	Message length is shorter or longer than the meter requires.
Checksum	548	Checksum error.
Parity	550	Wrong parity has been entered.
Calibration lockout	557	"S2-A" jumper has been removed (the printer may change to calibration).
EEPROM write lockout	549	Any write (W) command is issued to the meter and the external pull-up on the rear connector "P2" of the meter has been grounded.
Valid input	556	An illegal command value has been entered to the meter.

CAUTION: THE METER WILL NOT RESPOND TO A COMMAND IF THE COMMAND'S RECOGNITION CHARACTER DOES NOT MATCH WITH THE METER'S RECOGNITION CHARACTER.

15.15 RS-485 CONTROLLER MODE

The **RS-485 CONTROLLER** mode allows you to control other meters if identical protocol is used. The RS-485 bus can sequence through each of these devices and request a "V01" command from all devices with addresses 1 through 32, and print these to an RS-485 printer elsewhere on the bus.

15.15 RS-485 CONTROLLER MODE (Continued)

The actual maximum (upper limit) address the meter uses is set by its own RS-485 address, provided it is 32 or less.

You must have an RS-485 card installed in the meter to initiate the **RS-485 CONTROLLER** mode. Additionally, configure these bits as follows:

- * "CF1.8=1"
- * "BUS.4=1" (**MULTI-POINT** mode)
- * "BUS.7=1" (RS-485 board)

When you set these configuration bits correctly the meter forces a carriage return separator ("BUS.8=1") and **CONTINUOUS** mode ("BUS.5=0").

The meter transmits its own "V01" response. It then transmits its own recognition character, followed by address "01" and "V01" <CR>. Once you initiate the **RS-485 CONTROLLER** mode the meter transmits the following:

Note: The recognition character is "*".

1. <the meter's own V01 response>
2. "*01V01"<CR>
3. Another meter with address 01 and a "*" recognition character then responds to the "V01" command.

15.15 RS-485 CONTROLLER MODE (Continued)

4. The meter waits approximately 2 seconds (to give the requested unit time to respond), then repeats the following for the next address:

<the meter's own V01 response>
"*02V01"<CR>

The meter repeats this until it reaches the meters own serial address number "SER AD".

Note: If the SER AD is larger than 32, the meter defaults 32 as its upper limit address.

5. After completing all address locations the meter waits for the amount of seconds set by the SER TI menu item, then begins back at address 01 to begin the sequence again.

Example: 5 meters have the same RS-485 protocol on a bus (including this controller), and you would like to print out the meter readings from all these devices once a day unattended on a RS-485 printer, located elsewhere on the same bus.

1. Configure the controller for the last serial address: 005. The other 4 units would be set up for address 001 through 004.
2. Set controller's "SER TI" for 86,400, to set the print interval at 1 day (1 day = 86400 Seconds).

15.15 RS-485 CONTROLLER MODE (Continued)

Enable the CONTROLLER mode by setting "CF1.8=1", then configure all the units for **RS-485 MULTI-POINT** mode ("**BUS.4=1**", "**BUS.7=1**"). All units, including the printer, should have the same Baud rate, parity, and stop bit configuration.

This system enables you to interrogate other instruments on the RS-485 bus and request V01 responses from all of these instruments. If you hook up a printer in the loop, you may use this system for datalogging purposes without the use of other expensive computer products. All the instruments on the bus must have the same recognition character as the controller/timer, and no instrument may have an address higher than 32 (or higher than the SER AD).

15.16 ASCII CHARACTER CODES

Table 15-13. ASCII Codes

ROW		COL	8	1	2	3	4	5	6	7
		DB6-	0	0	0	0	0	0	0	0
		DB5-	0	0	1	1	0	0	1	1
		DB4-	0	1	0	1	0	1	0	1
JHEX	DEC	0000 0000 0200								
0	0	0000	NUL	DL0	SP	0	@	P	'	p
1	1	0001	SOH	DC1	!	1	A	Q	z	q
2	2	0010	STX	DC2	"	2	B	R	h	r
3	3	0011	ETX	DC3	#	3	C	S	c	s
4	4	0100	EOI	DC4	\$	4	D	T	d	t
5	5	0101	ENQ	NAK	%	5	E	U	e	u
6	6	0110	ACK	SYN	&	6	F	V	f	v
7	7	0111	DEL	ETB		7	G	W	g	w
8	8	1000	BS	CAN	!	8	H	X	h	x
9	9	1001	HT	EM	;	9	I	Y	i	y
A	10	1010	FF	SUB	*		J	Z	j	z
B	11	1011	VT	ESC	!		K	[k	l
C	12	1100	FT	ES	,	^	L	\	l	
D	13	1101	CR	GS	-	-	M]	m	!
E	14	1110	SO	RS		^	N	^	n	-
F	15	1111	SI	US	?	?	O		o	Del.

SECTION 16. ISOLATED PARALLEL BCD OUTPUT BOARD

The Isolated Parallel BCD Output Board produces binary-coded decimal output for direct connection to a printer or to an intelligent device, such as a PLC (Programmable Logic Controller).

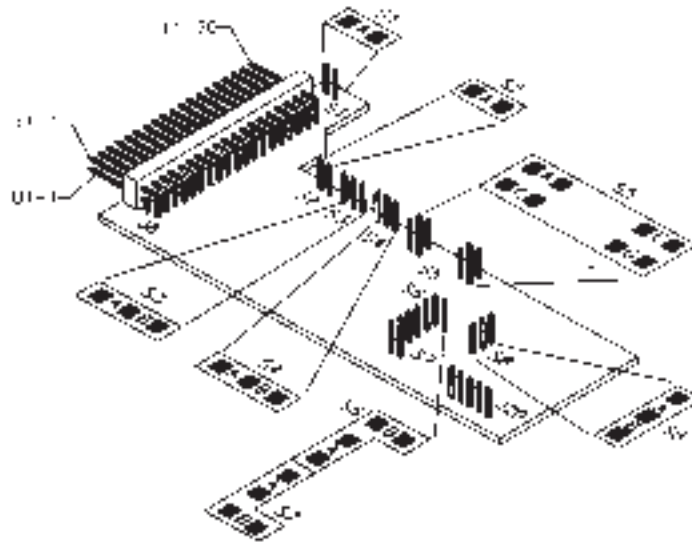

1

Figure 16-1. BCD Board Jumper Locations

16.1 SPECIFICATIONS

BCD Type	Isolated, stored, buffered, addressable, tri-state.
Digit Addressing	3 or 6 digits at a time
Output Level	TTL/CMOS-compatible, 10 LSTTL load
Power	External 5V dc for isolated BCD; internal non-isolated BCD

16.2 JUMPER LOCATIONS AND CONFIGURATIONS

Figure 16-1 shows the locations of Isolated Parallel BCD Output Board jumpers and Table 16-1 provides detail information for each jumper. Factory defaults are bold.

Table 16-1. BCD Board Jumpers/Functions

Jumper	Function
S1-A	Brings OVERFLOW signal to PR U18
S2-A	Enables 3-digit multiplex; removal enables 6-digit readout
S3-A	Enables 3-digit multiplex or 1-line board address
S3-B	Enables 4-line board address.
S4-A	Enables 3-digit multiplex
S4-B	Enables 6-digit readout
S5-A	PR-U20 must be low to enable board; removal enables board when high or open
S5-E	PR-U19 must be low to enable board; removal enables board when high or open
S5-G	PR-U14 must be low to enable board; removal enables board when high or open
S6-A S6-B S7-A S7-B	Selects internal power; removal selects isolated power
S8-A	Selects output data to be negative true
S8-B	Selects output data to be positive true

16.2 JUMPER LOCATIONS AND CONFIGURATIONS (Continued)

Table 16-2. P8 Assignments

Function	P-8 Pin	P-8 Pin	Function
BCD 400K	L-1	U-1	BCD 800K
BCD 100K	L-2	U-2	BCD 200K
ISO GND	L-3	U-3	SPARE
BCD 40K	L-4	U-4	BCD 80K
BCD 10K	L-5	U-5	BCD 20K
BCD 4K	L-6	U-6	BCD 8K
BCD 1K	L-7	U-7	BCD 2K
NOT USED	L-8	U-8	NOT USED
BCD 400	L-9	U-9	BCD 800
BCD 100	L-10	U-10	BCD 200
BCD 40	L-11	U-11	BCD 80
BCD 10	L-12	U-12	BCD 20
BCD 4	L-13	U-13	BCD 8
BCD 1	L-14	U-14	BCD 2
ISO GND	L-15	U-15	NOT USED
(not) DATA READY	L-16	U-16	AM/PM
ISO V+	L-17	U-17	(not) HOLD
OVERRIDE	L-18	U-18	OVERRIDE
ADDRESS (not) B4	L-19	U-19	ADDRESS (not) B8
ADDRESS (not) B1	L-20	U-20	ADDRESS (not) B2

16.3 50-LINE CABLE COMPATIBILITY

The 40 lines of P-8 are compatible with lines 9 through 48 of some 50-line busses. (The left-most 8 and right-most 2 are not used by this BCD option.)

16.4 ENABLING TRANSMISSION OF BCD DATA

The output configuration of the Isolated Parallel BCD Output Board is controlled by choice "CF1.5". "CF1.6" determines which BCD value is sent:

Output Configuration as set by "CF1.5" and "CF1.6".

Table 16-3. CF1.5 and CF1.6 Output Configurations

Choice	Setting	Resulting Action
"CF1.5="	1	BCD board is installed (required upon BCDboard installation)
"CF1.6="	0	Send timer display value to BCD board.
"CF1.6="	1	Send Real Time value to BCD board.

16.5 (not)HOLD CONTROL

P8-17 is the HOLD line, referenced to the same ground as the BCD output (on P8-L15 and P8-L3). Pulling this line low freezes the BCD outputs. This is useful for a slow reading device or for asymmetric cable delays. When released, all 6 digits of the BCD data are updated together.

16.6 (not) DATA READY TIMING PULSES

The tri-state BCD outputs are always valid to within a few nanoseconds; a single update pulse controls all digits.

To generate a timing marker, P8-L16, DATA READY, goes active low for approximately 200 us at the time of each update. The polarity of this line is NOT CHANGED by S8, the data polarity control jumper.

16.7 BRINGING OUT THE BCD ALARM LINES

Use P8-U18 to bring out ALARM 1, by installing jumper S1-A. If this line is used for another purpose by some other equipment on the BCD bus, remove this jumper.

Note: *ALARM 4, ALARM 3, ALARM 2 are wired to E5, E4, E3 respectively.*

16.8 THREE-DIGIT-AT-A-TIME MULTIPLEX

If you install jumpers S2-A, S3-A, and S4-A, P8-L20 and S5-C control the number of times the upper 3 digits of the 6-digit BCD value appear on the output line (P8-U9 through P8-LI4) .

If you install jumper S5-C, a LOW level on P8-L20 activates the upper 3 digit outputs; a high or open level disables them.

If you remove jumper S5-C, a high or open level on P8-L20 enables the upper 3 digits and a low level disables them. If you enable the upper 3 digits, you may enable the lower 3 digits in the same manner by jumper S5-A and P8-U20; they appear on the same 12 lines.

16.9 SIX DIGIT-AT-A-TIME BOARD ADDRESS

Remove Jumpers S2-A and S4-A for full parallel (6-digit) output. Install jumper S3-A to enable the outputs by line P8-L20 ALONE: A low level enables the outputs if you install jumper S5-C, and a high or open level does the job if S5-C is removed.

If you remove jumper S3-A, you enable the outputs only when you apply the selected 4-line address to P8-UI9, LI9, U20, and L20. Each of these 4 pins are exclusively-ORed with its jumper, and the consequent four outputs are ANDed to create a 1-of-16 ENABLE mode.

If you install jumper S5-A, P8-U20 must be LOW to enable the board.

If you install jumper S5-C, P8-L20 must be LOW to enable the board.

If you install jumper S5-E, P8-UI9 must be LOW to enable the board.

If you install jumper S5-G, P8-LI9 must be LOW to enable the board.

16.9 SIX DIGIT-AT-A-TIME BOARD ADDRESS (Continued)

If you remove any of these jumpers, the corresponding line must go HIGH or OPEN to assist the board to enable; if you remove all 4 jumpers the board outputs are enabled ONLY when all 4 lines are HIGH or OPEN. A ground on any of the 4 input lines causes the outputs to go to the high impedance state.

16.10 SELECTING DATA POLARITY: JUMPER S8

Insert the S8 jumper in S8-B (the usual shipping position) to make the output data positive-true.

Place the S8 jumper in S8-A to convert the data to negative-true.

16.11 APPLYING NON-ISOLATED POWER

Enable non-isolated power by installing jumpers S6-A, S6-B, S7-A, and S7-B. This bridges the isolation separation distance on the board. Current drawn is less than 10 mA.

To isolate these outputs from the other meter circuits, remove S6-A, S6-B, S7-A, and S7-B, and connect an external, nominal 5-V supply to P8-LI7, with its ground return connected to P8-L15.

16.12 DRIVING A PRINTER

Directly connect the 24 BCD lines for positive-true printers. If your printer has more than 6 digits, tie the unused inputs to ground or V+, or leave them open (whichever produces blanks in those locations).

SECTION 17. DUAL RELAY OUTPUT BOARD

The Dual Relay Output Board provides 2 isolated (354 V per IEC spacing, 500 test), 7-ampere form C electro-mechanical relays that enable alarm-triggered switching to an external device. Each relay can accommodate a single setpoint. Two hundred-Ohm 2500pf snubbers are provided for each normally open contact.

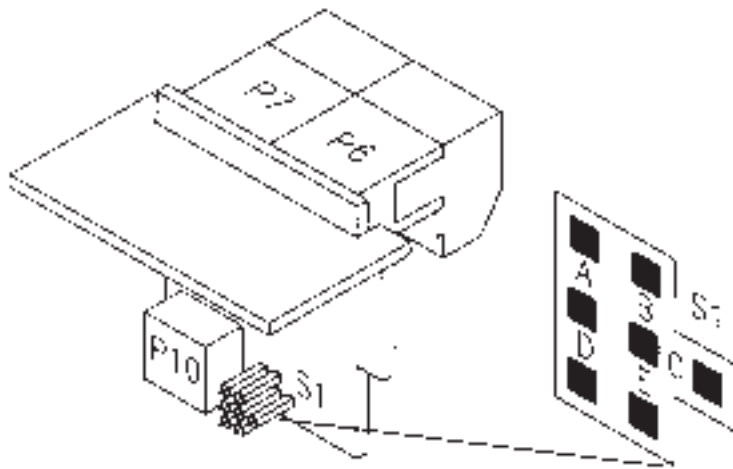

Figure 17-1. Dual Relay Output Board

17.1 SPECIFICATIONS

Output type	Dual Form C relays
Power Rating for resistive Loads	Normally open contact 8 amp; 30 V dc or 230 V ac Normally closed contact, 7 amp; 30 V dc or 230 V ac

17.2 JUMPER LOCATIONS AND CONFIGURATIONS

Figure 17-1 illustrates the locations of Dual Relay output Board jumpers, the P-10 plug connecting the board to the Main Board, and the positions of P6 and P7, the output plugs. Table 17-1 details jumper relay assignment. Relay 1 corresponds to the P6 Plug. Relay 2 corresponds to the P7 Plug. Defaults are bold.

Table 17-1. Dual Relay Board Jumpers

Jumper	Function
S1-A	Assigns Output 3 to Relay 1 (P6)
S1-B	Not Used
S1-C	Assigns Output 2 to Relay 2 (P7)
S1-D	Assigns Output 1 to Relay 1 (P6)
S1-E	Assigns Output 4 to Relay 2 (P7)

SECTION 18. FOUR RELAY OUTPUT BOARD

The Four Relay Output Board provides two isolated (354 V per IEC spacing, 500 test), 7-ampere form C and two 0.5-ampere form C electro-mechanical relays that enable alarm-triggered switching to an external device. Each relay accommodates a single alarm output. Two hundred-Ohm 2500pf snubbers are provided for each normally open contact.

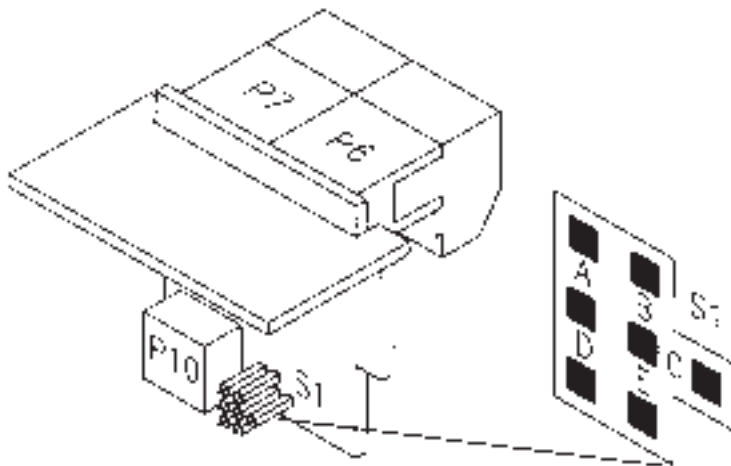

Figure 18-1. 4-Relay Board Jumper Locations

SECTION 18. FOUR-RELAY OUTPUT BOARD (Continued)

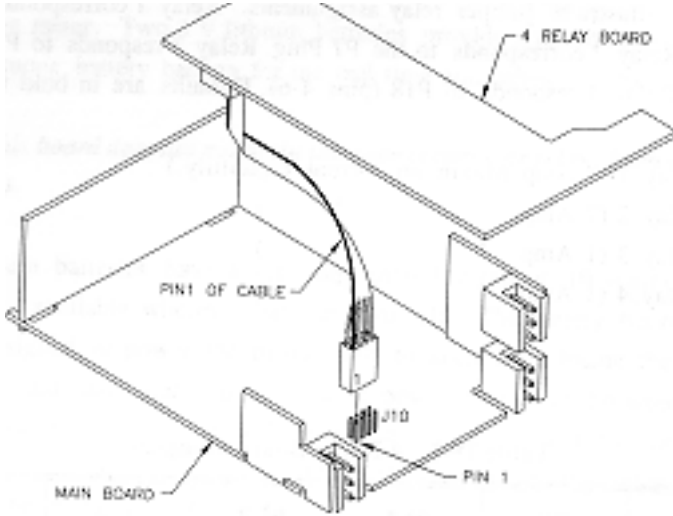

Figure 18-2. 4-Relay Board Installation

18.1 SPECIFICATIONS

Output type	Four Form C relays
Power Rating	
for resistive Loads	Two relays at P6 and P7
	Normally open contact 7 amp; 30 V dc or 230 V ac
	Normally closed contact, 7 amp; 30 V dc or 230 V ac
for resistive loads	Two relays at P8 and P9
	Normally open contact 1 amp; 30 V dc or 0.5 amp
125 V ac	Normally closed contact, 1 amp; 30V dc or 0.5 amp 125 V ac

18.2 JUMPER RELAY ASSIGNMENTS

Table 18-1 illustrates jumper relay assignments. Relay 1 corresponds to the P6 Plug. Relay 2 corresponds to the P7 Plug. Relay 3 responds to P18 (pins 1-3) and Relay 4 responds to P18 (pins 4-6). Defaults are in bold text.

K1 = Relay 1 (7 Amp Maximum current capability.)

K2 = Relay 2 (7 Amp “ ”)

K3 = Relay 3 (1 Amp “ ”)

K4 = Relay 4 (1 Amp “ ”)

Table 18-1. 4-Relay Board Jumpers

S1	S2	AL1	AL2	AL3	AL4
A.C *	A.C *	K1	K2	K3	K4
B,D	A.C	K1	K3	K1	K4
B,D	B,D	K1	K4	K2	K2
A.C	B,D	K1	K4	K3	K2

Factory default jumper positions are marked with *

SECTION 19. BATTERY BACKUP BOARD

The battery backup board is a 1.5" high by 3.5" wide plug-in board that fits inside the meter. Two 3 V lithium batteries provide a minimum of 25 hours of continuous battery backup for the real time and calendar meter functions.

Note: This board does not maintain the open collector or relay alarm outputs (if installed).

The lithium batteries have a very long shelf life (about 10 years), and are commonly available wherever batteries are sold. The battery backup board is not designed to power the meter, only to keep from losing the internal real time and date functions in case of power failure or brownout. The lithium batteries cannot be recharged and should be replaced as soon as possible if the meter displays a "BAT LO" message during setup. Meter displays the battery status in the RUN mode by pressing the REVIEW button.

19.1 BATTERY BOARD INSTALLATION

Note: Disconnect power from the meter when installing the battery option board.

1. Make sure that the S1-A jumper on the battery board is not installed. This jumper connects the battery voltage to the meter and should be connected after you install the battery board.

19.1 BATTERY BOARD INSTALLATION (Continued)

2. Remove the meter from its case. P13 on the battery board inserts into the J-13 pins on the main board (a row of pins located to the right of meter, looking at it from the rear). The battery board is held in position by a plastic guide on the rear of the display board.
3. Install the meter back into its case and apply AC power to the meter.
4. Connect the S1-A jumper on the battery board, through the slot in the case, to connect the battery board to the meter.
5. Set the time and date using the front-panel pushbuttons.

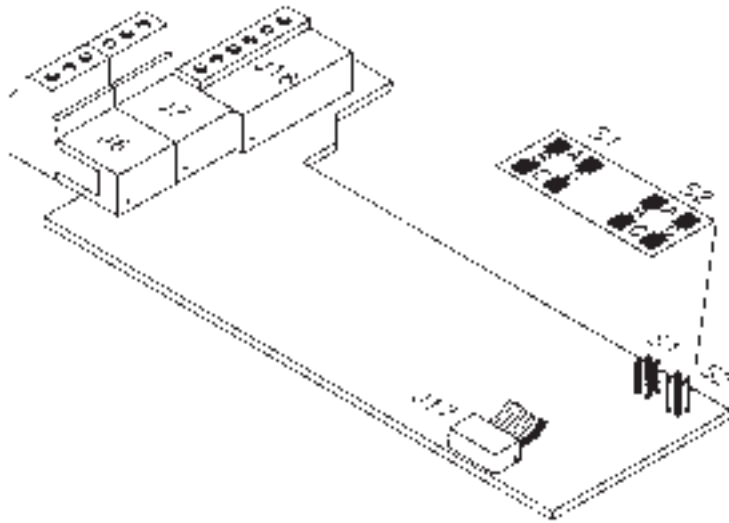

Figure 19-1. Battery Board Jumper and Battery Location

SECTION 20. ERROR MESSAGES

The meter has several built-in setup inspections. The meter performs these inspections before the unit switches to the RUN mode. Table 20-1 describes possible error codes and their descriptions, and if possible, a “fix” for the error.

Table 20-1. Error Messages

Error Codes	Description	Fix
ERR 01	February 29 entered in a non-leap year. Meter automatically sets the date to February 28.	Change to legal date.
ERR 04	A start value equals a stop value.	Press the MENU button and change the start or stop value.
ERR 05	Setpoint overflow in ELAPSE mode: SP 1 – SP 2 is larger than the limit values for the timer units selected.	Press the MENU button and lower value of suspect setpoint. The SETPTS button scrolls you through the setpoints (press the SETPTS button to save new setpoint values before proceeding).
WARN 01	One or more of your setpoints are set too high for the units you have selected.	Change setpoints to values within your timer unit's limits.
BAT 1.0	If a battery backup board is installed, indicates that the batteries are low.	Replace batteries.
NOSTOR	During configuration, indicates that the non-volatile memory has been locked out. The latest setup change is not stored in non-volatile memory.	Set CF1=4 to allow storage to non-volatile memory, or remove ground (low) from I2-10 until the time.

SECTION 21. SPECIFICATIONS

Display: Type 14 segment, red or green
Digit height 0.54-inch (13.7mm)
Dimming 100% and 50% brightness levels
Max resolution 0.01 seconds, programmable
Indicator lights 4 alarms indicating ON
or ACTIVE mode, and 2 AM/PM LED indicators,
1 Timer On LED indicator (RUN)

Power: AC Voltage 115V ac or 230V ac +/- 10%
AC frequency 50 or 60Hz
Consumption 6 Watts nominal, 9 Watts max
Power failure Real Time, Date, Timer Display
and Current Cycle value stored in nonvolatile
memory

Main

Board: Setpoint output 4 open collector transistors
Power rating 150 mA dc @ 1V sink, 30V when
open.

General: Input threshold 1V to 3.5V
Protection level 24V dc
Connection Two 3-socket input plugs
Input resistance 30k_ pull-up resistor to +5V

Display

Modes: 12-hour clock (Real Time)
24-hour clock (Real Time)
99-hour clock
99-day
999999-hour
9999.99-hour
99-minute
9999.99-minute
9999.99-seconds

Accuracy: Clock time base derived from 50Hz/60Hz line frequen-
cy.
Crystal time base +/- 50 PPM over full temperature range.

Operating Ambient Range: 32_F to 140_F (0_C to 60_C).

Case: Material 94V-0 UL-rated polycarbonate
Dimensions (Hx Wx D) 1.89 x 3.78 x 5.86 in.
(48 x 96 x 149 mm)

SECTION 21. SPECIFICATIONS (Continued)

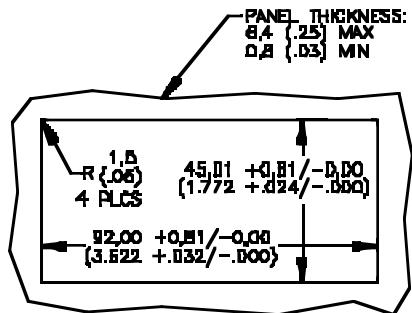

Figure 21-1. Panel Dimensions

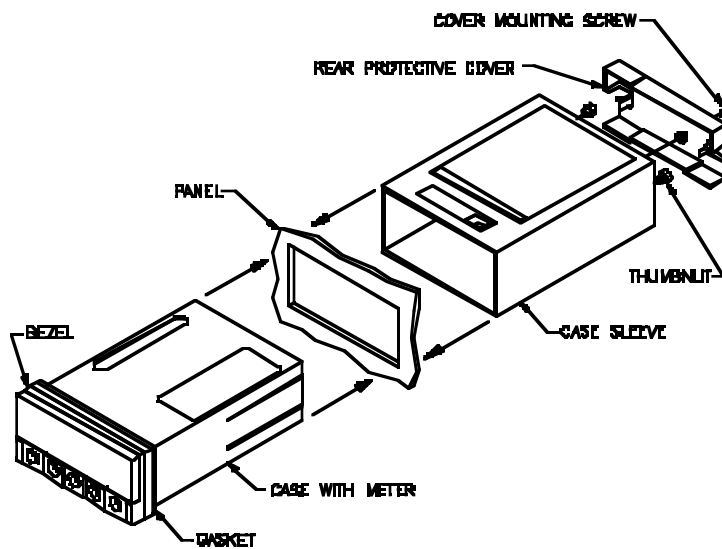

Figure 21-2. Panel Mount Assembly with Standard Bezel

21.1 SPECIFICATIONS (Continued)

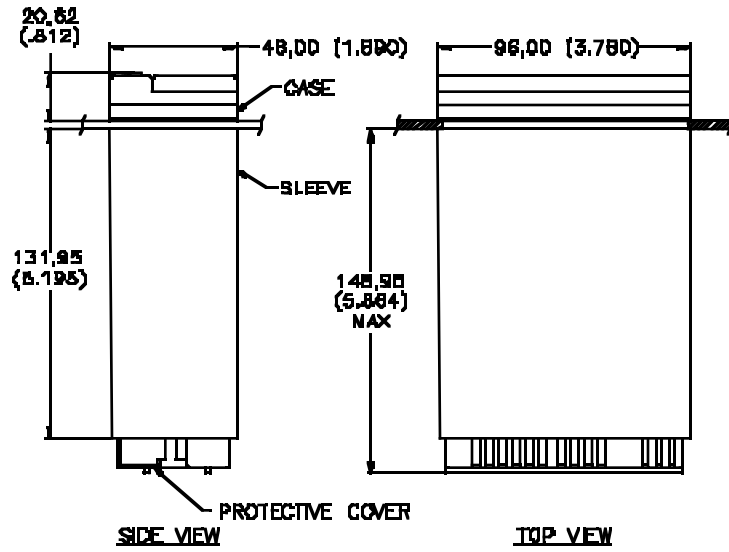

Figure 21-3. Meter Dimensions with Standard Bezel

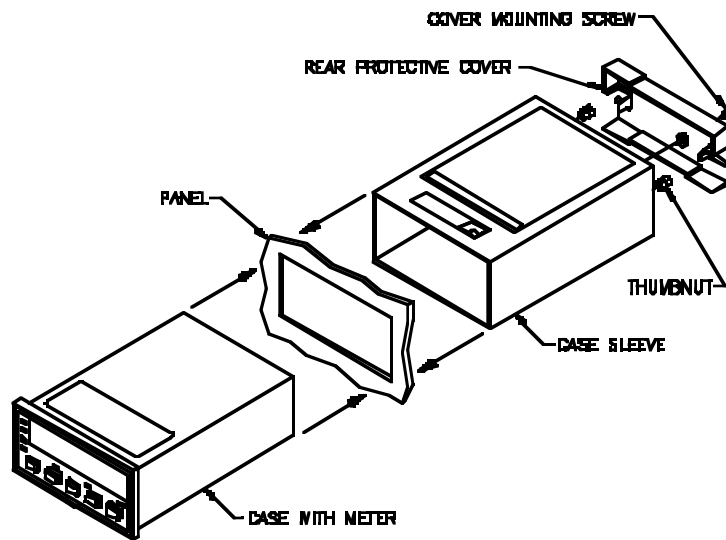

Figure 21-4. Panel Mount Assembly with Optional Housing

SPE

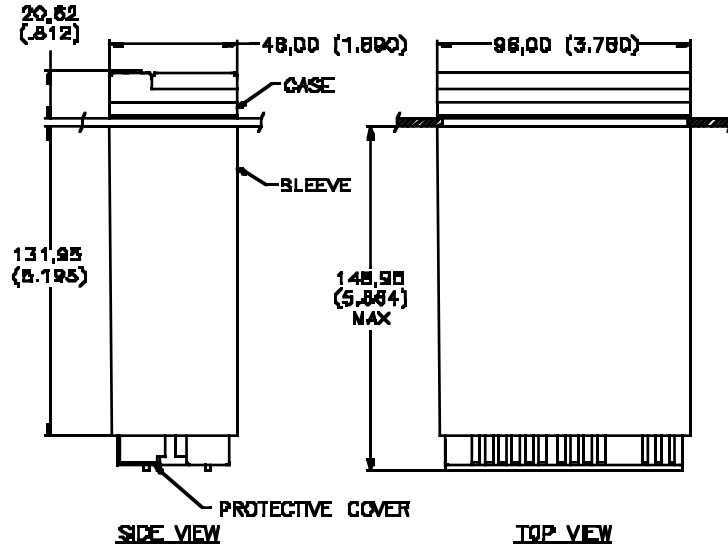

Figure 21-3.

Meter Dimensions with Standard Bezel

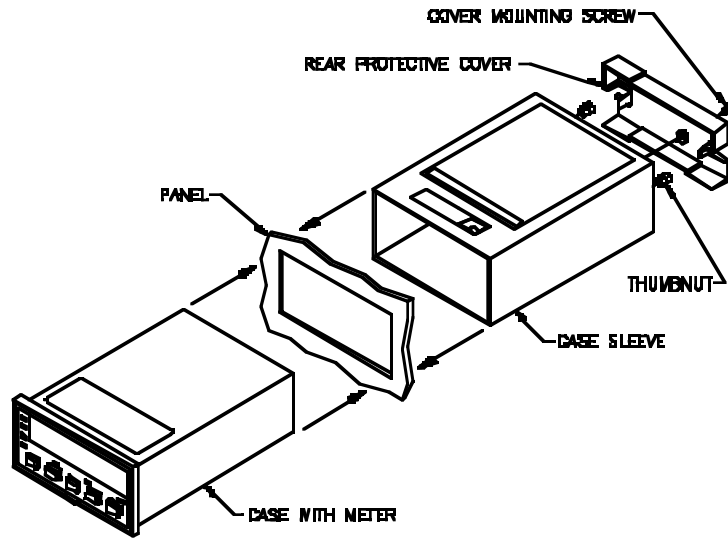

Figure 21-4. Panel Mount Assembly with Optional Housing

21.1 SPECIFICATIONS (Continued)

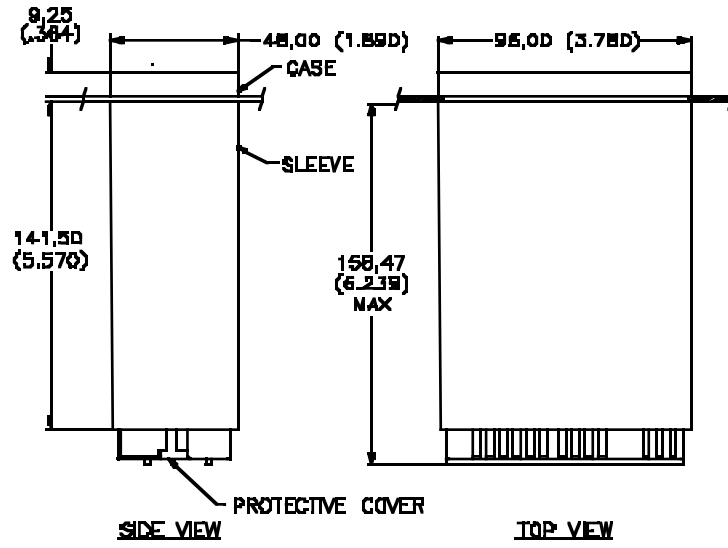

Figure 21-5. Meter Dimensions with Optional Housing

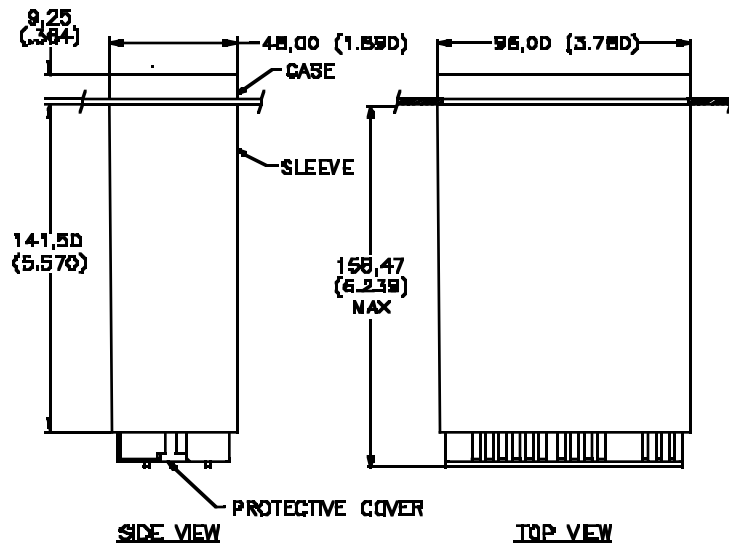

Figure 21-5. Meter Dimensions with Optional Housing